



NIT No.: TPNODL/OT/2021-22/143 Dtd.21/01/2022

Open Tender Notification

For

One Year of Rate Contract for Supply of various line and substation material accessories as per Specification for TPNODL.

Tender Enquiry No.: TPNODL/OT/2021-22/143 Dtd.21/01/2022

Due Date for Tender Fee: 12.02.2022. [15:00 Hrs.]

Due Date for Bid Submission: 15.02.2022 [15:00 Hrs.]

**TP NORTHERN ODISHA DISTRIBUTION LIMITED
(A TATA Power and Odisha Government Joint Venture)
Contracts & Material Management Department,
Corporate Office, Januganj, Balasore-756019**

Property of TPNODL – Not to be reproduced without prior written permission of TPNODL



NIT No.: TPNODL/OT/2021-22/143 Dtd.21/01/2022

Procedure to Participate in Tender

Tender Enquiry No- TPNODL/OT/2021-22/143

Tender Enquiry No.	Work Description	EMD (Rs.)	Tender Fee (Inclusive of GST) (Rs.)	Last Date and Time for payment of Tender Fee
NIT Number: TPNODL/OT/20 21-22/143	One Year of Rate Contract for Supply of various line and substation material accessories as per Specification for TPNODL	50,000	5000	12.02.2022; 15:00 Hrs

* EMD is exempted for MSMEs registered in the State of Odisha. ** MSMEs registered in the State of Odisha shall pay tender fee of Rs. 1,000/- including GST. For details of MSME norms, pls refer "Annexure IX (GCC)"

Please note that corresponding details mentioned in this document will supersede any other details mentioned anywhere else in the Tender Document.

Procedure to Participate in Tender.

Following steps to be done before "Last date and time for Payment of Tender Fee" as mentioned above:

1. Eligible and Interested Bidders to submit duly signed and stamped letter on Bidder's letter head indicating
 - a. Tender Enquiry number
 - b. Name of authorized person
 - c. Contact number
 - d. E-mail id
 - e. Details of submission of Tender Fee
 - f. GST Registration No
- g. Payment UTR No- Having Remark (Bidder Name_ NIT Number)

Property of TPNODL – Not to be reproduced without prior written permission of TPNODL



NIT No.: TPNODL/OT/2021-22/143 Dtd.21/01/2022

h. ANID & User ID of ARIBA System (If Any)

2. Non-Refundable Tender Fee, as indicated in table above, to be submitted in the form of Direct Deposit in the following bank account and submit the receipt along with a covering letter clearly indicating the Tender Reference/ Enquiry Number –

Beneficiary Name – TP Northern Odisha Distribution Limited

Bank Name – Union Bank of India

Branch Name – Balasore Branch

Account No – 500601010280332

IFSC Code – UBIN0550060

E-mail with necessary attachment to be sent to kartikchandra.behera@tpnodl.com with copy to hirusikesh.pradhan@tpnodl.com before last date and time for payment of Tender Fee.

Interested bidders to submit Tender Fee and Authorization Letter before Last date and time as indicated above, after which link from TPNODL E-Tender system (Ariba) will be shared for further communication and bid submission.

Please note all future correspondence regarding the tender, bid submission, bid submission date extension, Pre-bid query etc will happen only through TPNODL E-Tender system (Ariba). User manual to guide the bidders to submit the bid through E-Tender system (Ariba) is also enclosed.

No e-mail or verbal correspondence will be responded. All communication will be done strictly with the bidders who have done the above step to participate in the Tender.

Also it may be strictly noted that once date of “Last date and time for Payment of Tender Participation Fee” is lapsed no Bidder will be sent link from TPNODL E-Tender System (Ariba). Without this link vendor will not be able to participate in the tender. Any last moment request to participate in tender will not be entertained.

Any payment of Tender Fee / EMD by Bidder who have not done the prerequisite will not be refunded.

Also all future corrigendum to the said tender will be informed on Tender section on website <https://www.tpnodl.com>

Corporate office: Januganj, Balasore, Odisha-756019

Property of TPNODL – Not to be reproduced without prior written permission of TPNODL

CONTENTS OF THE ENQUIRY

S. NO.	PARTICULARS
1.	Event Information
2.	Evaluation Criteria
3.	Submission of Bid Documents
4.	Bid Opening & Evaluation process
5.	Award Decision
6.	Order of Preference/Contradiction
7.	Post Award Contract Administration
8.	Specifications and Standards
9.	General Conditions of Contract
10.	Safety
Annexures	
I.	Schedule of Items
II.	Technical Specifications
III.	Schedule of Deviations
IV.	Schedule of Commercial Specifications
V.	Document Check List
VI.	Acceptance Form for Participation in Reverse Auction Event
VII.	General Condition of Contract
VIII.	Inspection Test Plan
IX.	Tata Code of Conduct (TCoC)
X.	Environment & Sustainability Policy

1.0 Event Information

1.1 Scope of work

Open Tenders are invited through e-tender bidding process from interested and eligible bidders for entering into a Rate contract as defined below:

Tender Enquiry No.	Work Description	EMD (Rs.)	Tender Fee (Inclusive of GST)(Rs.)	Last Date and Time for payment of Tender Fee
TPNODL/OT/2021-22/143 Dtd.21/01/2021	One Year of Rate Contract for Supply of various line and substation material accessories as per Specification for TPNODL	50,000	5000	12.02.2022; 15:00 Hrs

1.2 Availability of Tender Documents

Please refer "Procedure to participate in the e-tender".

1.3 Calendar of Events

(a)	Last Date of receipt of Tender Fee	12.02.2022; 15:00 Hrs
(b)	Date & Time of Pre-Bid Meeting (If any)	Not Applicable due to COVID-19, Queries to be answered through e-mail/TPNODL Tender website.
(c)	Last Date of receipt of pre-bid queries, if any	07.02.2022 up to 15:00 Hrs
(d)	Last Date of Posting Consolidated replies to all the pre-bid queries as received	10.02.2022 up to 18:00 Hrs
(e)	Last date and time of receipt of Bids	15.02.2022 up to 15:00 Hrs
(f)	Date & Time of opening technical bids & EMD	15.02.2022 up to 15:30 Hrs
(g)	Date & Time of opening of Price of qualified bids	Will be notified to the successful bidders through our website / e-mail.

Note :- In the event of last date specified for submission of bids and date of opening of bids is declared as a closed holiday for TPNODL, the last date of submission of bids and date of opening of bids will be the following working day at appointed times.

Pre bid meeting shall be scheduled at TPNODL Corporate Office or Online. Same shall be communicated to the interested bidders post receipt of their Tender Fee.

1.4 Mandatory documents required along with the Bid

- 1.4.1 EMD of requisite value and validity.
- 1.4.2 Tender Fee in case the tender is downloaded from website
- 1.4.3 Requisite Documents for compliance to Qualification Criteria mentioned in Clause 1.7.
- 1.4.4 Drawing, Type Test details along with a sample of each item as specified at Annexure I (as applicable)
- 1.4.5 Duly signed and stamped 'Schedule of Deviations' as per Annexure III on bidder's letter head.
- 1.4.6 Duly signed and stamped 'Schedule of Commercial Specifications' as per Annexure IV on bidder's letter head.
- 1.4.7 Proper authorization letter/ Power of Attorney to sign the tender on the behalf of bidder.
- 1.4.8 Copy of PAN, GST, PF, ESI Registration and valid Labour License (In case any of these documents is not available with the bidder, same to be explicitly mentioned in the 'Schedule of Deviations')

Please note that in absence of any of the above documents, the bid submitted by a bidder shall be liable for rejection.

1.5 Deviation from Tender

Normally, the deviations to tender terms are not admissible and the bids with deviation are liable for rejection. Hence, the bidders are advised to refrain from taking any deviations on this Tender. Still in case of any deviations, all such deviations shall be set out by the Bidders, clause by clause in the 'Annexure III - Schedule of Deviations' and same shall be submitted as a part of the Technical Bid.

1.6 Right of Acceptance/ Rejection

Bids are liable for rejection in absence of following documents: -

- 1.6.1 EMD of requisite value and validity
- 1.6.2 Tender fee of requisite value
- 1.6.3 Price Bid as per the Price Schedule mentioned in Annexure-I
- 1.6.4 Necessary documents against compliance to Qualification Requirements mentioned at Clause 1.7 of this Tender Document.
- 1.6.5 Filled in Schedule of Deviations as per Annexure III
- 1.6.6 Filled in Schedule of Commercial Specifications as per Annexure IV
- 1.6.7 Receipt of Bid within the due date and time

TPNODL reserves the right to accept/reject any or all the bids without assigning any reason thereof.

1.7 Qualification Criteria

- 1.7.1 The bidder should have an average annual turnover of Rs. 1 crore in last 3 financial years (Any Three FY 17-18, 18-19, 19-20, 20-21). Copy of audited P&L Account to be submitted in this regard.

- 1.7.2 The bidder should have experience regarding supplied similar products as per tender BOQ at least 50 % of the turn over value during last three years. Copy of Purchase order / completion certificate to be submitted in this regard.
- 1.7.3 The bidder should have provide at least one performance Certificate from reputed power utilities in India in similar material. Within last 5 years
- 1.7.4 The bidder should be Manufacturers / Registered Traders / authorized by TPNODL. Also the bidder is supposed to have agreement with Manufacturer/ Service provider to provide support to TPNODL for any service & spares related issues during relevant guarantee/ warranty period as stipulated in the TPNODL specifications. Copy of self-undertaking shall be submitted in this regard.
- 1.7.5 TPNODL reserves the right to conduct pre dispatch inspection the said material as per BOQ as a proof of compliance to the technical specification.

1.8 Marketing Integrity

We have a fair and competitive marketplace. The rules for bidders are outlined in the General Condition of Contracts. Bidders must agree to these rules prior to participating. In addition to other remedies available, TPNODL reserves the right to exclude a bidder from participating in future markets due to the bidder's violation of any of the rules or obligations contained in the General Condition of Contracts. A bidder who violates the market place rules or engages in behavior that disrupts the fair execution of the marketplace, may result in restriction of a bidder from further participation in the marketplace for a length of time, depending upon the seriousness of the violation. Examples of violations include, but are not limited to:

- Failure to honor prices submitted to the marketplace
- Breach of terms as published in TENDER/NIT

1.9 BAs Confidentiality

All information contained in this tender is confidential and shall not be disclosed, published or advertised in any manner without written authorization from TPNODL. This includes all bidding information submitted to TPNODL. All tender documents remain the property of TPNODL and all BAs are required to return these documents to TPNODL upon request. BAs who do not honor these confidentiality provisions will be excluded from participating in future bidding events.

2.0 Evaluation Criteria

- The bids will be evaluated technically on the compliance to tender terms and conditions.
- The bids will be evaluated commercially on the overall all-inclusive lowest cost for the complete tender BOQ as calculated in Schedule of Items [Annexure I]. TPNODL reserves the right to split the order line item wise and / or quantity wise among more than one Bidder. Hence all bidders are advised to quote their most competitive rates against each line item
- Bidder has to mandatorily quote of each line item as per schedule of item [Annexure-I]. Failing to do so TPNODL may reject the bid.

Property of TPNODL – Not to be reproduced without prior written permission of TPNODL



NIT No.: TPNODL/OT/2021-22/143 Dtd.21/01/2022

NOTE: In case of a new bidder not registered, factory inspection and evaluation shall be carried out to ascertain bidder's manufacturing capability and quality procedures. However TPNODL reserves the right to carry out factory inspection and evaluation for any bidder prior to technical qualification. In case a bidder is found as Disqualified in the factory evaluation, their bid shall not be evaluated any further and shall be summarily rejected. The decision of TPNODL shall be final and binding on the bidder in this regard.

2.1 Price Variation Clause: The prices as finalized shall remain firm during the entire contract period.

3.0 Submission of Bid Documents

3.1 Bid Submission

Bidders are requested to submit their offer in line with this Tender document. TPNODL shall respond to the clarification raised by various bidders and the replies will be sent to all participating bidders through e-mail.

Bids shall be submitted in 3 (Three) parts:

FIRST PART: "EMD" of Rs. 50000/- (**Rupees Fifty Thousand only**). The EMD shall be valid for 210 days from the due date of bid submission in the form of BG. The EMD has to be strictly in the format as mentioned in General Condition of Contract, failing which it shall not be accepted and the bid as submitted shall be liable for rejection. A separate non-refundable tender fee of stipulated amount also needs to be transferred online through NEFT/ RTGS in case the tender document is downloaded from our website.

TPNODL Bank Details for transferring Tender Fee and EMD is as below:

Beneficiary Name – TP Northern Odisha Distribution Limited
Bank Name – Union Bank of India
Branch Name – Balasore Branch
Account No – 500601010280332
IFSC Code – UBIN0550060

*In case the EMD is in the form of BG, **EMD Original Hard Copy** shall be delivered at the following address in Envelope clearly indicating Tender Reference Number, Name of Tender and Bidder Name before opening of the Bid.*

The Envelop shall be addresses to:

H.O.D. (Contracts)
TP NORTHERN ODISHA DISTRIBUTION LIMITED
(A Tata Power and Odisha Government Joint Venture)
Corporate office: Januganj, Balasore, Odisha-756019

The envelop shall also bear the Name & Address of the bidder along with our Tender No. and subject.

SECOND PART: "TECHNICAL BID" shall contain the following documents:

- a) Documentary evidence in support of qualifying criteria
- b) Technical literature/GTP/Type test report etc. *(if applicable)*
- c) Qualified manpower available
- d) Testing facilities *(if applicable)*
- e) No Deviation Certificate as per the Annexure III – Schedule of Deviations
- f) Acceptance to Commercial Terms and Conditions viz Delivery schedule/ Contract period, payment terms etc. as per the Annexure IV – Schedule of Commercial Specifications.
- g) Quality Assurance Plan/Inspection Test Plan for supply items *(if applicable)*
- h) Acceptance of Annexure II-Scope of work and service level agreement.

The technical bid shall be properly indexed and is to be submitted through TPNODL E-tender platform (Ariba) only. Hard copy of Technical Bids need not be submitted.

THIRD PART: "PRICE BID" shall contain only the price details and strictly in format as mentioned in Annexure I along with explicit break up of basic prices, Taxes & duties, Freight etc. In case any discrepancy is observed between the item description stated in Schedule of Items mentioned in the tender and the price bid submitted by the bidder, the item description as mentioned in the tender document (to the extent modified through Corrigendum issued if any) shall prevail. Price Bid is to be submitted in soft copy through TPNODL E-Tendering system (Ariba) only. Hard copy of Price Bid not be submitted.

SIGNING OF BID DOCUMENTS:

The bid must contain the name, residence and place of business of the person or persons making the bid and must be signed and sealed by the Bidder with his usual signature. The names of all persons signing should also be typed or printed below the signature.

The Bid being submitted must be signed by a person holding a Power of Attorney authorizing him to do so, certified copies of which shall be enclosed.

The Bid submitted on behalf of companies registered with the Indian Companies Act, for the time being in force, shall be signed by persons duly authorized to submit the Bid on behalf of the Company and shall be accompanied by certified true copies of the resolutions, extracts of Articles of Association, special or general Power of Attorney etc. to show clearly the title, authority and designation of persons signing the Bid on behalf of the Company. Satisfactory evidence of authority of the person signing on behalf of the Bidder shall be furnished with the bid.



NIT No.: TPNODL/OT/2021-22/143 Dtd.21/01/2022

A bid by a person who affixes to his signature the word 'President', 'Managing Director', 'Secretary', 'Agent' or other designation without disclosing his principal will be rejected.

The Bidder's name stated on the Proposal shall be the exact legal name of the firm.

3.2 Contact Information

All the bidders are requested to send their pre-bid queries (if any) against this tender through e-mail within the stipulated timelines. The consolidated reply to all the queries received shall be posted on TPNODL website by the stipulated timelines as detailed in calendar of events.

Communication Details:

Package Owner - Contracts

Name: Mr. Kartik Chandra Behera

Contact No.: 8908972132

E-Mail ID: kartikchandra.behera@tpnodl.com

HOD Contracts/AGM-E Contracts

Name: Mr. Hrusikesh Pradhan

Contact No: 9438906036

E-Mail ID: hrusikesh.pradhan@tpnodl.com

Bidders are strictly advised to communicate with Package Owner through TPNODL E-tender System (Ariba) only. They need to pay Tender Participation Fee to receive the Ariba log-in.

3.3 Bid Prices

Bidders shall quote for the entire Scope of Supply/ work with a break up of prices for individual items and Taxes & duties. The bidder shall complete the appropriate Price Schedules included herein, stating the Unit rate for each item & total price with taxes, duties & freight up to destination at various sites of TPNODL. The all-inclusive prices offered shall be inclusive of all costs as well as Duties, Taxes and Levies paid or payable during the execution of the supply / work, breakup of price constituents.

The quantity break up shown else-where other than Price Schedule is tentative. The bidder shall ascertain himself regarding material required for completeness of the entire work. Any items not indicated in the price schedule but which are required to complete the job as per the Technical Specifications/ Scope of Work/ SLA mentioned in the tender, shall be deemed to be included in prices quoted.

Applicable GST to be specified clearly.

The quantity break up shown else-where other than Price Schedule is tentative. The bidder shall ascertain himself regarding material required for completeness of the entire work. Any items not indicated in the price schedule but which are required to complete the job as per the Technical Specifications/ Scope of Work/ SLA mentioned in the tender, shall be deemed to be included in prices quoted.

3.4 Bid Currencies

Prices shall be quoted in Indian Rupees Only.

3.5 Period of Validity of Bids

Bids shall remain valid for 180 days from the due date of submission of the bid.

Notwithstanding clause above, the TPNODL may solicit the Bidder's consent to an extension of the Period of Bid Validity. The request and responses thereto shall be made in writing.

3.6 Alternative Bids

Bidders shall submit Bids, which comply with the Bidding documents. Alternative bids will not be considered. The attention of Bidders is drawn to the provisions regarding the rejection of Bids in the terms and conditions, which are not substantially responsive to the requirements of the bidding documents.

3.7 Modifications and Withdrawal of Bids

The bidder is not allowed to modify or withdraw its bid after the Bid's submission. The EMD as submitted along with the bid shall be liable for forfeiture in such event

3.8 Earnest Money Deposit (EMD)

The bidder shall furnish, as part of its bid, an EMD amounting as specified in the tender. The EMD is required to protect the TPNODL against the risk of bidder's conduct which would warrant forfeiture.

The EMD shall be denominated in any of the following form:

- Online transfer of requisite amount through NEFT/ RTGS.
- Bank Guarantee valid for 210 days after due date of submission.

The EMD shall be forfeited in case of:

a) The bidder withdraws its bid during the period of specified bid validity.

Or

b) The case of a successful bidder, if the Bidder does not

- i) accept the Rate contract , or
- ii) furnish the required performance security BG

3.9 Type Tests (if applicable)

The type tests specified in TPNODL specifications should have been carried out within five years prior to the date of opening of technical bids and test reports are to be submitted along with the bids. If type tests carried out are not within the five years prior to the date of bidding, the bidder will arrange to carry out type tests specified, at his cost. The decision to accept/ reject such bids rests with TPNODL.

4.0 Bid Opening & Evaluation process

4.1 Process to be confidential

Information relating to the examination, clarification, evaluation and comparison of Bids and recommendations for the award of a contract shall not be disclosed to Bidders or any other persons not officially concerned with such process. Any effort by a Bidder to influence the TPNODL's processing of Bids or award decisions may result in the rejection of the Bidder's Bid.

4.2 Technical Bid Opening

Bids shall be opened as per the schedule mentioned in Calendar of Events. In case of limited tenders, the bids shall be opened internally by TPNODL. Owing to COVID Scenario, in case of Open Tenders also, the bids shall be opened internally by TPNODL. Technical bid must not contain any cost information whatsoever.

First the "EMD" will be checked. Bids without EMD/ cost of tender (if applicable) of required amount/ validity in prescribed format, shall be rejected.

Next, the technical bid of the bidders who have furnished the requisite EMD will be opened, one by one. The salient particulars of the techno commercial bid will be read out at the sole discretion of TPNODL.

4.3 Preliminary Examination of Bids/ Responsiveness

TPNODL will examine the Bids to determine whether they are complete, whether any computational errors have been made, whether required sureties have been furnished, whether the documents have been properly signed, and whether the Bids are generally in order. TPNODL may ask for submission of original documents in order to verify the documents submitted in support of qualification criteria.

Arithmetical errors will be rectified on the following basis: If there is a discrepancy between the unit price and the total price per item that is obtained by multiplying the unit price and quantity, the unit price shall prevail and the total price per item will be corrected. If there is a discrepancy between the Total Amount and the sum of the total price per item, the sum of the total price per item shall prevail and the Total Amount will be corrected.

Prior to the detailed evaluation, TPNODL will determine the substantial responsiveness of each Bid to the Bidding Documents including production capability and acceptable quality of the Goods offered. A substantially responsive Bid is one, which conforms to all the terms and conditions of the Bidding Documents without material deviation.



NIT No.: TPNODL/OT/2021-22/143 Dtd.21/01/2022

Bid determined as not substantially responsive will be rejected by the TPNODL and/or the TPNODL and may not subsequently be made responsive by the Bidder by correction of the non-conformity.

4.4 Techno Commercial Clarifications

Bidders need to ensure that the bids submitted by them are complete in all respects. To assist in the examination, evaluation and comparison of Bids, TPNODL may, at its discretion, ask the Bidder for a clarification on its Bid for any deviations with respect to the TPNODL specifications and attempt will be made to bring all bids on a common footing. All responses to requests for clarification shall be in writing and no change in the price or substance of the Bid shall be sought, offered or permitted owing to any clarifications sought by TPNODL. After all techno commercial issues are clarified, the date of price bid opening will be intimated to the technically accepted bidders and same shall also be notified at TPNODL website.

4.5 Price Bid Opening

Price bids will be opened at the stipulated date and time. The EMD of the bidder withdrawing or substantially altering his offer at any stage after the technical bid opening will be forfeited at the sole discretion of TPNODL without any further correspondence in this regard.

4.6 Reverse Auctions

TPNODL reserves the right to conduct the reverse auction (instead of public opening of price bids) for the products / services being asked for in the tender and reserves the rights to conduct the manual negotiation with the BA who is declared L1 after Reverse Auction. The terms and conditions for such reverse auction events shall be as per the Acceptance Form attached as Annexure VI of this document. The bidders along with the tender document shall mandatorily submit a duly signed copy of the Acceptance Form attached as Annexure VI as a token of acceptance for the same.

5.0 Award Decision

TPNODL will award the contract to the successful bidder whose bid has been determined to be the lowest-evaluated responsive bid as per the Evaluation Criterion mentioned at Clause 2.0. The Cost for the said calculation shall be taken as the all-inclusive cost quoted by bidder in Annexure I (Schedule of Items) subject to any corrections required in line with Clause 4.3 above. The decision to place award of contract order/LOI solely depends on TPNODL on the cost competitiveness across multiple lots, quality, delivery and bidder's capacity, in addition to other factors that TPNODL may deem relevant.

TPNODL reserves all the rights to award the contract to one or more bidders so as to meet the requirement or nullify the award decision without assigning any reason thereof.

In case any BAs is found unsatisfactory during the Contract period, the award will be cancelled and TPNODL reserves the right to award other BAs who are found fit.

6.0 Order of Preference/Contradiction:

In case of contradiction in any part of various documents in tender, following shall prevail in order of preference:

1. Schedule of Items (Annexure I)
2. Post Award Contract Administration (Clause 7.0)
3. Submission of Bid Documents (Clause 3.0)
4. Scope of Work and SLA (Annexure VII)-If any
5. Technical Specifications (Annexure II)
6. Inspection Test Plan (Annexure VIII)-If any
7. Acceptance Form for Participation in Reverse Auction (Annexure VI)
8. General Conditions of Contract (Annexure IX)

7.0 Post Award Contract Administration

Special Conditions of Contract

1. Rate contract shall be valid for a period of 1 years from the placement of Contract. Release Order (RO) shall be placed as per the requirement of TPNODL. Rate shall remain firm as per Clause No. 2.1, till the validity of Rate Contract.
2. Within 15 days from the date of issue of RC to BA, BA shall submit PBG equivalent to 5% of the contract value which shall be valid till warranty period plus one month.
3. Warranty of material shall be 24 months from the date of last installation or 30 months from the date of last Supply
4. The delivery schedule shall be 60 days from the date of issuing of RO. First RO shall be placed after GTP/Drawing approval. The selected bidder shall submit the GTP/drawing within 7 days of issue of Rate Contract.
5. Physical Inspection of the materials will be carried out at destination after delivery. The materials not found suitable as per technical specification during inspection, will be rejected.
6. TPNODL reserves the rights to short close the issued Release Order / Purchase Order, in case of any quality issues.
7. Payment Terms- within 45 days from the date of supply of materials against the RO.
8. Any change in statutory taxes, duties and levies shall be borne by TPNODL.
9. TPNODL appreciates and welcomes the engagement/employment of persons from SC/ST community or any other deprived section of society by their BAs.
10. Quotation in all BOM items is mandatory, and bid shall be rejected if any line item of BOQ is found blank in price bid.
11. All the terms and conditions of TPNODL GCC- Supply shall be applicable.

7.2 Drawing Submission & Approval

Any relevant drawings and GTPs need to be submitted within 10 Days of receipt of firm Order by the successful bidder to TPNODL for approval.

In case, re-submission of drawings is required on request of TPNODL, same needs to be submitted back to TPNODL within 5 days of such request.

7.3 Delivery Terms

The delivery schedule shall be 60 days from the date of issuing of RO. First RO shall be placed after GTP/Drawing approval. The selected bidder shall submit the GTP/drawing within 7 days of issue of Rate Contract.

7.4 Warranty Period

Warranty of material shall be 24 months from the date of last installation or 30 months from the date of last Supply or as per Technical Specification.

7.5 Payment Terms

On delivery of the materials in good condition and certification of acceptance by certified official, Associate shall submit the Bills/ Invoices in original in the name of TP Northern Odisha Distribution Ltd. to Invoice Desk. The payment shall be released within 45 days from the date of supply of materials against the RO and submission of certified bills/ invoices.

7.6 Climate Change

Significant quantities of waste are generated during the execution of project and an integrated approach for effective handling, storage, transportation and disposal of the same shall be adopted. This would ensure the minimization of environmental and social impact in order to combat the climate change.

7.7 Ethics

- TPNODL is an ethical organization and as a policy TPNODL lays emphasis on ethical practices across its entire domain. Bidder should ensure that they should abide by all the ethical norms and in no form either directly or indirectly be involved in unethical practice.
- TPNODL work practices are governed by the Tata Code of Conduct which emphasizes on the following:
 - We shall select our suppliers and service providers fairly and transparently.
 - We seek to work with suppliers and service providers who can demonstrate that they share similar values. We expect them to adopt ethical standards comparable to our own.
 - Our suppliers and service providers shall represent our company only with duly authorized written permission from our company. They are expected to abide by the Code in their interactions with, and on behalf of us, including respecting the confidentiality of information shared with them.
 - We shall ensure that any gifts or hospitality received from, or given to, our suppliers or service providers comply with our company's gifts and hospitality policy.
 - We respect our obligations on the use of third party intellectual property and data.

Bidder is advised to refer GCC attached at Annexure IX for more information.



NIT No.: TPNODL/OT/2021-22/143 Dtd.21/01/2022

Any ethical concerns with respect to this tender can be reported to the following e-mail ID: ceoffice@tpnodl.com

8.0 Specification and standards

As per Annexure I & II

9.0 General Condition of Contract

Any condition not mentioned above shall be applicable as per GCC for Service attached along with this tender at Annexure IX.

10.0 Safety

Safety related requirements as mentioned in our safety Manual put in the Company's website which can be accessed by:

[http:// www.tpnodl.com](http://www.tpnodl.com)

All Associates shall strictly abide by the guidelines provided in the safety manual at all relevant stages during the contract period.

All jobs are this tender have to be executed strictly in compliance to the Safety terms and Conditions of TP Northern Odisha Distribution Limited. Please refer attached Safety terms and conditions, Annexure-X, for details. Violation of Safety norms will result in Penalty as mentioned in the above document.

ANNEXURE-I

Schedule for Items

S. No	Item Description	Qty	UoM	HSN Code	Unit Price (Rs.)	GST (Rs.)	All incl. Unit Price (Rs.)	All incl. BOQ Price (Rs.)
1.	BOARD DANGER 33KV	1,000	EA					
2	CONNECTOR T 33KV FOR 100 TO 100 SQMM	200	EA					
3	Connector T 33 KV for 232 to 100 SQMM	50	EA					
4	CONNECTOR T 33KV FOR 100 TO 80 SQMM	100	EA					
5	BIRD FLAPPER	250	EA					
6	SOCKET CRIMPING AL 16 SQMM CABLE	1,000	EA					
7	SOCKET CRIMPING AL 25 SQMM	1,000	EA					
8	SOCKET CRIMPING AL 50 SQMM CABLE	1,000	EA					
9	SOCKET CRIMPING AL 95 SQMM CABLE	500	EA					
10	SOCKET CRIMPING AL 120 SQMM CABLE	500	EA					
11	SOCKET CRIMPING AL 150 SQMM CABLE	500	EA					
12	SOCKET CRIMPING AL 185 SQMM CABLE	500	EA					
13	SOCKET CRIMPING AL 240 SQMM CABLE	1,000	EA					
14	SOCKET CRIMPING AL 300 SQMM CABLE	500	EA					
15	BINDING WIRE ALUMINIUM	2,000	KG					
16	CLAMP 33KV BACK (GI)	3,000	EA					
Total Value All Incl. Taxes								

NOTE:

- The quantity mentioned above is for evaluation purpose only and may vary during the execution.
- The unit price with GST in column no. 7, is landed price FOR TPNODL Odisha Locations. Exact delivery location shall be specified in the Release Order.
- The bidders are advised to quote prices strictly in the above format. Failing to do so, bids are liable for rejection.
- The bidder must fill each and every column of the above format. ***Mentioning “extra/inclusive” in any of the column may lead for rejection of the price bid.***
- No cutting/ overwriting in the prices is permissible.

Annexure II

Technical Specifications
Attached separately with this tender

ANNEXURE III

Schedule of Deviations

*Bidders are advised to refrain from taking any deviations on this TENDER. Still in case of any deviations, all such deviations from this tender document shall be set out by the Bidders, Clause by Clause in this schedule and submit the same as a part of the **Technical Bid**.*

Unless specifically mentioned in this schedule, the tender shall be deemed to confirm the TPNODL's

S. No.	Clause No.	Tender Clause Details	Details of deviation with justifications

specifications:

By signing this document we hereby withdraw all the deviations whatsoever taken anywhere in this bid document and comply to all the terms and conditions, technical specifications, scope of work etc. as mentioned in the standard document except those as mentioned above.

Seal of the Bidder:

Signature:

Name:

ANNEXURE IV

Schedule of Commercial Specifications

(The bidders shall mandatorily fill in this schedule and enclose it with the offer Part I: Technical Bid. In the absence of all these details, the offer may not be acceptable.)

S. No.	Particulars	Remarks
1.	Prices firm or subject to variation (If variable indicate the price variation clause with the ceiling if applicable)	Firm / Variable
1a.	If variable price variation on clause given	Yes / No
1b.	Ceiling	----- %
1c.	Inclusive of Excise Duty	Yes / No (If Yes, indicate % rate)
1d.	GST applicable at concessional rate	Yes / No (If Yes, indicate % rate)
1e.	Octroi payable extra	Yes / No (If Yes, indicate % rate)
1f.	Inclusive of transit insurance	Yes / No
2.	Delivery	Weeks / months
3.	Guarantee clause acceptable	Yes / No
4.	Terms of payment acceptable	Yes / No
5.	Performance Bank Guarantee acceptable	Yes / No
6.	Liquidated damages clause acceptable	Yes / No
7.	Validity (180 days) (From the date of opening of technical bid)	Yes / No
8.	Inspection during stage of manufacture	Yes / No
9.	Rebate for increased quantity	Yes / No (If Yes, indicate value)
10.	Change in price for reduced quantity	Yes / No (If Yes, indicate value)
11.	Covered under Small Scale and Ancillary Industrial Undertaking Act 1992	Yes / No (If Yes, indicate, SSI Reg'n No.)

ANNEXURE V

Checklist of all the documents to be submitted with the Bid

Bidder has to mandatorily fill in the checklist mentioned below:-

S. No.	Documents attached	Yes / No / Not Applicable
1	EMD of required value	
2	Tender Fee as mentioned in this RFQ	
3	Company profile/ organogram	
4	Signed copy of this RFQ as an unconditional acceptance	
5	Duly filled schedule of commercial specifications (Annexure IV)	
6	Sheet of commercial/ technical deviation if any (Annexure III)	
7	Balance sheet for the last completed three financial years; mandatorily enclosing Profit & loss account statement	
8	Acknowledgement for Testing facilities if available (duly mentioned on bidder letter head)	
9	List of Machine/ tools with updated calibration certificates if applicable	
10	Details of order copy (duly mentioned on bidder letter head)	
11	Order copies as a proof of quantity executed	
12	Details of Type Tests if applicable (duly mentioned on bidder letter head)	
13	All the relevant Type test certificates as per relevant IS/ IEC (CPRI/ ERDA/ other certified agency) if applicable	
14	Project/ Supply Completion certificates	
15	Performance certificates	
16	Client Testimonial/ Performance Certificates	
17	Credit rating/ Solvency certificate	
18	Undertaking regarding non blacklisting (On company letter head)	
19	List of trained/ Untrained Manpower	



NIT No.: TPNODL/OT/2021-22/143 Dtd.21/01/2022

Annexure VI

Acceptance Form for Participation In Reverse Auction Event

(To be signed and stamped by the bidder)

In a bid to make our entire procurement process more fair and transparent, TPNODL intends to use the reverse auctions as an integral part of the entire tendering process. All the bidders who are found as technically qualified based on the tender requirements shall be eligible to participate in the reverse auction event.

The following terms and conditions are deemed as accepted by the bidder on participation in the bid event:

1. TPNODL shall provide the user id and password to the authorized representative of the bidder. *(Authorization Letter in lieu of the same shall be submitted along with the signed and stamped Acceptance Form).*
2. TPNODL will make every effort to make the bid process transparent. However, the award decision by TPNODL would be final and binding on the supplier.
3. The bidder agrees to non-disclosure of trade information regarding the purchase, identity of TPNODL, bid process, bid technology, bid documentation and bid details.
4. The bidder is advised to understand the auto bid process to safeguard themselves against any possibility of non-participation in the auction event.
5. In case of bidding through Internet medium, bidders are further advised to ensure availability of the entire infrastructure as required at their end to participate in the auction event. Inability to bid due to telephone line glitch, internet response issues, software or hardware hangs, power failure or any other reason shall not be the responsibility of TPNODL.
6. In case of intranet medium, TPNODL shall provide the infrastructure to bidders. Further, TPNODL has sole discretion to extend or restart the auction event in case of any glitches in infrastructure observed which has restricted the bidders to submit the bids to ensure fair & transparent competitive bidding. In case of an auction event is restarted, the best bid as already available in the system shall become the start price for the new auction.
7. In case the bidder fails to participate in the auction event due any reason whatsoever, it shall be presumed that the bidder has no further discounts to offer and the initial bid as submitted by the bidder as a part of the tender shall be considered as the bidder's final no regret offer. Any offline price bids received from a bidder in lieu of non-participation in the auction event shall be outrightly rejected by TPNODL.
8. The bidder shall be prepared with competitive price quotes on the day of the bidding event.
9. The prices as quoted by the bidder during the auction event shall be inclusive of all the applicable taxes, duties and levies and shall be FOR at TPNODL site.
10. The prices submitted by a bidder during the auction event shall be binding on the bidder.
11. No requests for time extension of the auction event shall be considered by TPNODL.

Property of TPNODL – Not to be reproduced without prior written permission of TPNODL

12. The original price bids of the bidders shall be reduced on pro-rata basis against each line item based on the final all inclusive prices offered during conclusion of the auction event for arriving at Contract amount.

Signature & Seal of the Bidder

Annexure VII

Scope of Work & SLA

As mentioned in annexure I & II

Annexure VIII

Inspection Test Plan

NA

Annexure IX

GCC Supply

Attached along with the tender

TPNODL <small>TP NORTHERN ODISHA DISTRIBUTION LIMITED</small> <small>(A Tata Power and Odisha Government Joint Venture)</small>	TP NORTHERN ODISHA DISTRIBUTION LIMITED		
	TECHNICAL SPECIFICATIONS		
Doc. Title	SPECIFICATION FOR DANGER BOARD		
Doc. No:	ENG-GEN-009	Eff. Date: 16.11.2021	
Rev No:	00	Page 1 of 7	
Prepared by:	Reviewed by:	Approved by:	Issued by:

CONTENTS

1. SCOPE
2. APPLICABLE STANDARDS
3. CLIMATIC CONDITIONS OF THE INSTALLATION
4. GENERAL TECHNICAL REQUIREMENTS
5. GENERAL CONSTRUCTIONS
6. MARKING
7. TESTS
8. TYPE TEST CERTIFICATES
9. PRE-DISPATCH INSPECTION
10. INSPECTION AFTER RECEIPT AT STORES
11. GUARANTEE
12. PACKING
13. TENDER SAMPLE
14. QUALITY CONTROL
15. MINIMUM TESTING FACILITIES
16. MANUFACTURING ACTIVITIES
17. SPARES, ACCESSORIES AND TOOLS
18. DRAWINGS AND DOCUMENTS
19. GUARANTEED TECHNICAL PARTICULARS
20. SCHEDULE OF DEVIATIONS

Initiator	<i>Geeyakanta Mohanty</i>	HOD (Engineering)	<i>Sanku P.D.</i>
-----------	---------------------------	-------------------	-------------------

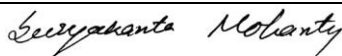

TPNODL <small>TP NORTHERN ODISHA DISTRIBUTION LIMITED</small> <small>(A Tata Power and Odisha Government Joint Venture)</small>		TP NORTHERN ODISHA DISTRIBUTION LIMITED	
		TECHNICAL SPECIFICATIONS	
Doc. Title		SPECIFICATION FOR DANGER BOARD	
Doc. No:	ENG-GEN-009	Eff. Date: 16.11.2021	
Rev No:	00	Page 2 of 7	
Prepared by:	Reviewed by:	Approved by:	Issued by:

1.	SCOPE	<p>This specification covers technical requirements of design, manufacture, testing at manufacturer's works, packing, forwarding, supply and unloading at stores/site, performance of danger board.</p>																																																		
2.	APPLICABLE STANDARDS	<p>The equipment covered by this specification shall unless otherwise stated, be designed, manufactured and tested in accordance with the latest editions of the following Indian, International Standards and shall conform to the regulations of the local authorities. The danger plate shall comply with the Indian Standard IS 2551- 1982.</p>																																																		
3.	CLIMATIC CONDITIONS OF THE INSTALLATION	<table style="width: 100%; border-collapse: collapse;"> <tr> <td style="width: 5%;">i.</td> <td style="width: 70%;">Maximum Ambient Temperature</td> <td style="width: 10%;"></td> <td style="width: 15%; text-align: right;">50°c</td> </tr> <tr> <td>ii.</td> <td>Maximum daily average ambient temperature</td> <td></td> <td style="text-align: right;">40°c</td> </tr> <tr> <td>iii.</td> <td>Minimum Ambient Temperature</td> <td></td> <td style="text-align: right;">2°c</td> </tr> <tr> <td>iv.</td> <td>Maximum humidity</td> <td></td> <td style="text-align: right;">99.7%</td> </tr> <tr> <td>v.</td> <td>Minimum humidity</td> <td></td> <td style="text-align: right;">15%</td> </tr> <tr> <td>vi.</td> <td>Average Annual Rainfall</td> <td></td> <td style="text-align: right;">1800mm</td> </tr> <tr> <td>vii.</td> <td>Average wind speed prevailing in the area</td> <td></td> <td style="text-align: right;">200kmph</td> </tr> <tr> <td>viii.</td> <td>Average Thunderstorms prevailing in the area</td> <td></td> <td style="text-align: right;">70 days per annum</td> </tr> <tr> <td>ix.</td> <td>Average Dust storms prevailing in the area</td> <td></td> <td style="text-align: right;">20 days per annum</td> </tr> <tr> <td>x.</td> <td>Average number of rainy days per annum</td> <td></td> <td style="text-align: right;">160</td> </tr> <tr> <td>xi.</td> <td>Maximum Altitude above sea level</td> <td></td> <td style="text-align: right;">1200m</td> </tr> <tr> <td>xii.</td> <td>Rainy months</td> <td></td> <td style="text-align: right;">June to October</td> </tr> </table> <p>The atmosphere across coastal divisions of TPNODL is very saline, laden with salt, acid and dust suspended during dry months and subjected to fog in cold months.</p>			i.	Maximum Ambient Temperature		50°c	ii.	Maximum daily average ambient temperature		40°c	iii.	Minimum Ambient Temperature		2°c	iv.	Maximum humidity		99.7%	v.	Minimum humidity		15%	vi.	Average Annual Rainfall		1800mm	vii.	Average wind speed prevailing in the area		200kmph	viii.	Average Thunderstorms prevailing in the area		70 days per annum	ix.	Average Dust storms prevailing in the area		20 days per annum	x.	Average number of rainy days per annum		160	xi.	Maximum Altitude above sea level		1200m	xii.	Rainy months		June to October
i.	Maximum Ambient Temperature		50°c																																																	
ii.	Maximum daily average ambient temperature		40°c																																																	
iii.	Minimum Ambient Temperature		2°c																																																	
iv.	Maximum humidity		99.7%																																																	
v.	Minimum humidity		15%																																																	
vi.	Average Annual Rainfall		1800mm																																																	
vii.	Average wind speed prevailing in the area		200kmph																																																	
viii.	Average Thunderstorms prevailing in the area		70 days per annum																																																	
ix.	Average Dust storms prevailing in the area		20 days per annum																																																	
x.	Average number of rainy days per annum		160																																																	
xi.	Maximum Altitude above sea level		1200m																																																	
xii.	Rainy months		June to October																																																	
4.	GENERAL TECHNICAL REQUIREMENTS	<table border="1" style="width: 100%; border-collapse: collapse;"> <thead> <tr> <th style="width: 5%;"></th> <th style="width: 40%;">DESCRIPTION</th> <th style="width: 15%;">UNITS</th> <th style="width: 40%;">REQUIREMENTS</th> </tr> </thead> <tbody> <tr> <td>1.</td> <td>Plate material</td> <td></td> <td>Mild steel</td> </tr> <tr> <td>2.</td> <td>Plate thickness, min</td> <td>mm</td> <td>1.6</td> </tr> <tr> <td>3.</td> <td>Front side paint</td> <td></td> <td>Vitreous enameled white</td> </tr> <tr> <td>4.</td> <td>Letters/ figure/skull/cross bones colour</td> <td></td> <td>Red color</td> </tr> <tr> <td>5.</td> <td>Rear side of plate</td> <td></td> <td>Enameled</td> </tr> <tr> <td>6.</td> <td>Dimension</td> <td>mm</td> <td>250x200</td> </tr> <tr> <td>7.</td> <td>Corners of the plate</td> <td></td> <td>Rounded off</td> </tr> </tbody> </table>				DESCRIPTION	UNITS	REQUIREMENTS	1.	Plate material		Mild steel	2.	Plate thickness, min	mm	1.6	3.	Front side paint		Vitreous enameled white	4.	Letters/ figure/skull/cross bones colour		Red color	5.	Rear side of plate		Enameled	6.	Dimension	mm	250x200	7.	Corners of the plate		Rounded off																
	DESCRIPTION	UNITS	REQUIREMENTS																																																	
1.	Plate material		Mild steel																																																	
2.	Plate thickness, min	mm	1.6																																																	
3.	Front side paint		Vitreous enameled white																																																	
4.	Letters/ figure/skull/cross bones colour		Red color																																																	
5.	Rear side of plate		Enameled																																																	
6.	Dimension	mm	250x200																																																	
7.	Corners of the plate		Rounded off																																																	
5.	GENERAL CONSTRUCTIONS	<p>5.1. Dimensions: 5.1.1 For 415V, 11kV, 33kV and 66kV voltage installations: 250x200mm (see figure given in Annexure). 5.1.2 All letterings shall be centrally spaced. The dimensions of the letters, figures and their respective positions shall be as given in figure. The size of each letter in the word in each language, and the spacing between them for purposes of scribing shall be so chosen that they are uniformly written in the space earmarked for them. 5.1.3 The corners of the plate shall be rounded off. 5.1.4 The locations of the fixing holes shall be left to the choice of the user.</p> <p>LANGUAGES ODIA: the word recommended to denote danger in <i>Odia</i> and the type of lettering are</p>																																																		

Initiator		HOD (Engineering)	
-----------	---	-------------------	---

 TP NORTHERN ODISHA DISTRIBUTION LIMITED		TP NORTHERN ODISHA DISTRIBUTION LIMITED	
		TECHNICAL SPECIFICATIONS	
Doc. Title		SPECIFICATION FOR DANGER BOARD	
Doc. No:	ENG-GEN-009	Eff. Date: 16.11.2021	
Rev No:	00	Page 3 of 7	
Prepared by:	Reviewed by:	Approved by:	Issued by:

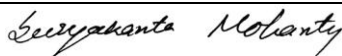
		<p>indicated in the specimen danger notice plates as shown in the figure. ENGLISH: for denoting in English, the type of lettering recommended is as shown in the figure.</p>
6.	NAME PLATE AND MARKING	<p>The essential information that would be necessary to identify the manufacturer of the danger board shall be marked, in such a manner and position on the plates that it does not interfere with the other information. The danger board shall also be marked with ISI certification mark. “PROPERTY OF TPNODL” to be written in blue color (PANTONE 300C) along with the logo.</p>
7.	TESTS	<p>General 7.0.1 In order to ensure that the notice plates conform to this specification, the following essential tests are specified. The number of samples to be tested shall be as agreed to between the supplier and the user. 7.0.2 the following shall constitute the tests: a) Visual examination b) Dimensional check c) Test for weather proneness. 7.1 Visual Examination The samples of notice shall be examined visually for conformity to the various requirements of this standard in respect of the works and letters used their relative positive and size. The color of the paint used shall be visually compared with the signal red color as specified in IS:5-1978 7.2 Dimensional Check The dimension of the plate, its thickness and the size of lettering, figures, etc. shall conform generally to the stipulations in 5.1.2 to 5.1.4 7.3 Tests for weather proneness For the purpose of verifying color retention of the vitreous enamel coatings, the method of test specified in IS 8709-1977 shall apply.</p>
8.	TYPE TEST CERTIFICATES	<p>Supplies shall be tested and five duly attested/certified copies of test certificates for respective items shall be submitted for approval and issuing Material Dispatch Clearance Certificate called MDCC.</p>
9.	PRE-DISPATCH INSPECTION	<p>A) TESTS: the material shall be subjected to following tests: 1) Visual Inspection B) The Material shall be subject to inspection by a duly authorized representative of the TPNODL. Inspection may be made at any stage of manufacture at the discretion of the purchaser and the equipment, if found unsatisfactory as to workmanship or material, the same is liable to rejection. Bidder shall grant free access to the places of manufacture to TPNODL’s representatives at all times when the work is in progress. Inspection by the TPNODL or its authorized representatives shall not relieve the bidder of his obligation of furnishing equipment in accordance with the specifications. Material shall be dispatched after specific MDCC (Material Dispatch Clearance Certificate) is issued by TPNODL. Following documents shall be sent along with material: a. Test reports</p>

Initiator		HOD (Engineering)	
-----------	---	-------------------	---

TPNODL <small>TP NORTHERN ODISHA DISTRIBUTION LIMITED (A Tata Power and Odisha Government Joint Venture)</small>		TP NORTHERN ODISHA DISTRIBUTION LIMITED	
		TECHNICAL SPECIFICATIONS	
Doc. Title		SPECIFICATION FOR DANGER BOARD	
Doc. No:	ENG-GEN-009	Eff. Date: 16.11.2021	
Rev No:	00	Page 4 of 7	
Prepared by:	Reviewed by:	Approved by:	Issued by:

		<ul style="list-style-type: none"> b. MDCC issued by TPNODL c. Invoice in duplicate d. Packing list e. Drawings & catalogue f. Guarantee / Warrantee card g. Delivery Challan h. Other Documents (as applicable).
10.	INSPECTION AFTER RECEIPT AT STORES	The material received at TPNODL store will be inspected for acceptance and shall be liable for rejection, if found different from the reports of the pre-dispatch inspection and one copy of the report shall be sent to Engineering & Contracts department
11.	GUARANTEE	<p>Bidder shall stand guarantee towards design, materials, workmanship & quality of process/ manufacturing of items under this contract for due and intended performance of the same, as an integrated product delivered under this contract. In the event any defect is found by the Purchaser up to a period of at least 48 months from the date of commissioning or 60 months from the date of last supplies made under the contract whichever is later. Bidder shall be liable to undertake to replace/rectify such defects at its own costs, within mutually agreed time frame, and to the entire satisfaction of the Purchaser, failing which the Purchaser will be at liberty to get it replaced/rectified at Bidder's risks and costs and recover all such expenses plus the Purchaser's own charges (@ 20% of expenses incurred), from the Bidder or from the "Security cum Performance Deposit" as the case may be.</p> <p>Bidder shall further be responsible for 'free replacement' for another period of THREE years from the end of the guarantee period for any 'Latent Defects' if noticed and reported by the Purchaser</p>
12.	PACKING	Suppliers shall ensure that all the equipment's covered by this specification shall be prepared for rail/road transport (local equipment) and be packed in such a manner as to protect it from damage in transit.
13.	TENDER SAMPLE	As and when required.
14.	QUALITY CONTROL	The bidder shall submit with the offer Quality assurance plan indicating the various stages of inspection, the tests and checks which will be carried out on the material.
15.	TESTING FACILITIES	Supplier/Manufacturer shall have adequate in house testing facilities for carrying out all routine tests & acceptance tests as per relevant International / Indian standards.
16.	MANUFACTURING ACTIVITIES	The successful bidder will have to submit the bar chart for various manufacturing activities clearly elaborating each stage, with quantity. This bar chart should be in line with the Quality assurance plan submitted with the offer. This bar chart will have to be submitted within 15 days from the release of the order.
17.	SPARES, ACCESSORIES AND TOOLS	The bidder shall provide a list of complete set of accessories and tools required for erection and maintenance of danger board plate along with the installation procedure.

Initiator	<i>Suryakanta Mohanty</i>	HOD (Engineering)	<i>Sanku P.D.</i>
-----------	---------------------------	-------------------	-------------------

TPNODL TP NORTHERN ODISHA DISTRIBUTION LIMITED <small>(A Tata Power and Odisha Government Joint Venture)</small>	TP NORTHERN ODISHA DISTRIBUTION LIMITED		
	TECHNICAL SPECIFICATIONS		
Doc. Title	SPECIFICATION FOR DANGER BOARD		
Doc. No:	ENG-GEN-009	Eff. Date: 16.11.2021	
Rev No:	00	Page 5 of 7	
Prepared by:	Reviewed by:	Approved by:	Issued by:

18.	DRAWINGS AND DOCUMENTS	<p>Following documents shall be prepared based on TPNODL specifications and statutory requirements with complete BOM and shall be submitted with the bid:</p> <ol style="list-style-type: none"> a) Completely filled in Technical Particulars. b) General description of the equipment and all components including brochures. c) Type test Certificates d) Experience List. <p>After the contract, four (4) copies of the drawings, drawn to scale, describing the equipment in detail shall be forwarded for approval and shall subsequently provide four (4) complete sets of final drawings, one of which shall be auto positive suitable for Reproduction, before the dispatch of the equipment. Soft copy (Compact Disk CD) of all the drawing, GTP, test certificates shall be submitted after the final approval of the same To the purchaser.</p>																										
19.	GENERAL TECHNICAL PARTICULARS	<table border="1" style="width: 100%; border-collapse: collapse;"> <thead> <tr> <th style="width: 10%;">SI.No.</th> <th style="width: 45%;">DESCRIPTION</th> <th style="width: 15%;">UNITS</th> <th style="width: 30%;">REQUIREMENTS</th> </tr> </thead> <tbody> <tr> <td>1.</td> <td>Plate material</td> <td></td> <td rowspan="7" style="text-align: center; vertical-align: middle;">To be furnished by the bidder</td> </tr> <tr> <td>2.</td> <td>Plate thickness, min</td> <td>mm</td> </tr> <tr> <td>3.</td> <td>Front side paint</td> <td></td> </tr> <tr> <td>4.</td> <td>Letters/ figure/skull/cross bones color</td> <td></td> </tr> <tr> <td>5.</td> <td>Rear side of plate</td> <td></td> </tr> <tr> <td>6.</td> <td>Dimension</td> <td>mm</td> </tr> <tr> <td>7.</td> <td>Corners of the plate</td> <td></td> </tr> </tbody> </table>	SI.No.	DESCRIPTION	UNITS	REQUIREMENTS	1.	Plate material		To be furnished by the bidder	2.	Plate thickness, min	mm	3.	Front side paint		4.	Letters/ figure/skull/cross bones color		5.	Rear side of plate		6.	Dimension	mm	7.	Corners of the plate	
SI.No.	DESCRIPTION	UNITS	REQUIREMENTS																									
1.	Plate material		To be furnished by the bidder																									
2.	Plate thickness, min	mm																										
3.	Front side paint																											
4.	Letters/ figure/skull/cross bones color																											
5.	Rear side of plate																											
6.	Dimension	mm																										
7.	Corners of the plate																											

Initiator	<i>Suryakanta Mohanty</i>	HOD (Engineering)	<i>Sandip P.D.</i>
-----------	---------------------------	-------------------	--------------------

TPNODL <small>TP NORTHERN ODISHA DISTRIBUTION LIMITED (A Tata Power and Odisha Government Joint Venture)</small>	TP NORTHERN ODISHA DISTRIBUTION LIMITED		
	TECHNICAL SPECIFICATIONS		
Doc. Title	SPECIFICATION FOR DANGER BOARD		
Doc. No:	ENG-GEN-009	Eff. Date: 16.11.2021	
Rev No:	00	Page 6 of 7	
Prepared by:	Reviewed by:	Approved by:	Issued by:

20. **SCHEDULE OF DEVIATIONS**

(TO BE ENCLOSED WITH TECHNICAL BID)

All deviations from this specification shall be set out by the Bidders, clause by Clause in this schedule. Unless specifically mentioned in this Schedule, the tender shall be deemed to confirm the purchaser's specifications:

S. No	Clause No.	Details of deviation with justifications

We confirm that there are no deviations apart from those detailed above.

Seal of the Company:

Initiator	<i>Suryakanta Mohanty</i>	HOD (Engineering)	<i>Sandip P.D.</i>
-----------	---------------------------	-------------------	--------------------

TPNODL TP NORTHERN ODISHA DISTRIBUTION LIMITED <small>(A Tata Power and Odisha Government Joint Venture)</small>	TP NORTHERN ODISHA DISTRIBUTION LIMITED		
	TECHNICAL SPECIFICATIONS		
Doc. Title	SPECIFICATION FOR DANGER BOARD		
Doc. No:	ENG-GEN-009	Eff. Date: 16.11.2021	
Rev No:	00		Page 7 of 7
Prepared by:	Reviewed by:	Approved by:	Issued by:

Initiator		HOD (Engineering)	
-----------	---	-------------------	---

TPNODL TP NORTHERN ODISHA DISTRIBUTION LIMITED <small>(A Tata Power and Odisha Government Joint Venture)</small>	TP NORTHERN ODISHA DISTRIBUTION LIMITED		
	TECHNICAL SPECIFICATIONS		
Doc. Title	TECHNICAL SPECIFICATION FOR 33 KV T-CONNECTOR		
Doc. No:	ENG-HV-032	Eff. Date: 20.12.2021	
Rev No:	00	Page 1 of 12	
Prepared by:	Reviewed by:	Approved by:	Issued by:

CONTENTS

- 1.0 SCOPE
- 2.0 APPLICABLE STANDARDS
- 3.0 CLIMATIC CONDITIONS OF THE INSTALLATION
- 4.0 GENERAL TECHNICAL REQUIREMENTS
- 5.0 BILL OF MATERIALS
- 6.0 NAME PLATE AND MARKING
- 7.0 TESTS
- 8.0 TYPE TEST CERIFICATES
- 9.0 PRE-DISPATCH INSPECTION
- 10.0 INSPECTION AFTER RECEIPT AT STORE
- 11.0 GUARANTEE
- 12.0 PACKING
- 13.0 TENDER SAMPLE
- 14.0 QUALITY CONTROL
- 15.0 MINIMUM TESTING FACILITIES
- 16.0 MANUFACTURING ACTIVITIES
- 17.0 SPARES, ACCESSORIES AND TOOLS
- 18.0 DRAWING AND DOCUMENTS
- 19.0 GUARANTEED TECHNICAL PARTICULARS
- 20.0 SCHEDULE OF DEVIATIONS

Initiator	<i>Seeyakanta Mohanty</i>	HOD (Engineering)	<i>Santosh P.D.</i>
-----------	---------------------------	-------------------	---------------------

 TPNODL TP NORTHERN ODISHA DISTRIBUTION LIMITED <small>(A Tata Power and Odisha Government Joint Venture)</small>	TP NORTHERN ODISHA DISTRIBUTION LIMITED		
	TECHNICAL SPECIFICATIONS		
Doc. Title	TECHNICAL SPECIFICATION FOR 33 KV T-CONNECTOR		
Doc. No:	ENG-HV-032	Eff. Date: 20.12.2021	
Rev No:	00	Page 2 of 12	
Prepared by:	Reviewed by:	Approved by:	Issued by:

1.0 SCOPE:

This specification covers the technical requirements of design, manufacture, construction, testing at manufacturer's works, packing, forwarding, supply and unloading at site/store and of T-Connector. T-connectors for Various Sizes of AAAC & ACSR Conductor Viz., 100-100 sq.mm, 232-100 Sq.mm, 100-80 sq.mm covered under this specification.



2.0 APPLICABLE STANDARDS:

The equipment covered by this specification shall unless otherwise stated, be designed, manufactured and tested in accordance with the latest editions of the following Indian, International Standards and shall conform to the regulations of the local Statutory authorities:

IS 617 (1975) | Aluminium and Aluminium alloys ingots and casting for general engineering purposes.

3.0 CLIMATIC CONDITION OF THE INSTALLATION:

i.	Maximum Ambient Temperature	50°c
ii.	Maximum daily average ambient temperature	40°c
iii.	Minimum Ambient Temperature	2°c
iv.	Maximum humidity	99.7%
v.	Minimum humidity	15%
vi.	Average Annual Rainfall	1800mm
vii.	Average wind speed prevailing in the area	200kmph
viii.	Average Thunderstorms prevailing in the area	70 days per annum
ix.	Average Dust storms prevailing in the area	20 days per annum
x.	Average number of rainy days per annum	160
xi.	Maximum Altitude above sea level	1200m
xii.	Rainy months	June to October

Initiator		HOD (Engineering)	
-----------	---	-------------------	---

 TPNODL TP NORTHERN ODISHA DISTRIBUTION LIMITED <small>(A Tata Power and Odisha Government Joint Venture)</small>	TP NORTHERN ODISHA DISTRIBUTION LIMITED		
	TECHNICAL SPECIFICATIONS		
Doc. Title	TECHNICAL SPECIFICATION FOR 33 KV T-CONNECTOR		
Doc. No:	ENG-HV-032	Eff. Date: 20.12.2021	
Rev No:	00	Page 3 of 12	
Prepared by:	Reviewed by:	Approved by:	Issued by:

The atmosphere across coastal divisions of TPNODL is very saline, laden with salt, acid and dust suspended during dry months and subjected to fog in cold months.

4.0 GENERAL TECHNICAL REQUIREMENTS:

Standard to which material shall conform	IS 5561
Material used in manufactured and reference to IS to which the material shall conform	Aluminium Alloy A-6 grade, IS-617 (1975)
Method of manufacture	Al. alloy Casting
Rated normal current of the clamps	As per the normal rated current of AAAC/ACSR conductor
Min. no. of Dips- fastner	4 Dips- 1 minute each
Packing detail	Double gunny bags
General tolerance	±5 %

5. BILL OF MATERIALS

SL. NO.	DESCRIPTION	MATERIAL	GRADE	SURFACE TREATMENT	QTY
1	CLAMP	ALUMINIUM ALLOY	LM-6, IS:617	-	1 SET
2	KEEPER	ALUMINIUM ALLOY	LM-6, IS: 617	-	1 SET
3	M12 NUT AND BOLT	M.S.	IS : 1367	HDG	8 SETS
4	M12 FLAT WASHER	M.S.	IS: 2062	HDG	8 NOS
5	M12 SPRING WASHER	SPRING STEEL	IS: 4072	E.G.	8 NOS

Initiator	<i>Suryakanta Mohanty</i>	HOD (Engineering)	<i>Sanku P.D.</i>
-----------	---------------------------	-------------------	-------------------

TPNODL TP NORTHERN ODISHA DISTRIBUTION LIMITED <small>(A Tata Power and Odisha Government Joint Venture)</small>	TP NORTHERN ODISHA DISTRIBUTION LIMITED		
	TECHNICAL SPECIFICATIONS		
Doc. Title	TECHNICAL SPECIFICATION FOR 33 KV T-CONNECTOR		
Doc. No:	ENG-HV-032	Eff. Date: 20.12.2021	
Rev No:	00	Page 4 of 12	
Prepared by:	Reviewed by:	Approved by:	Issued by:

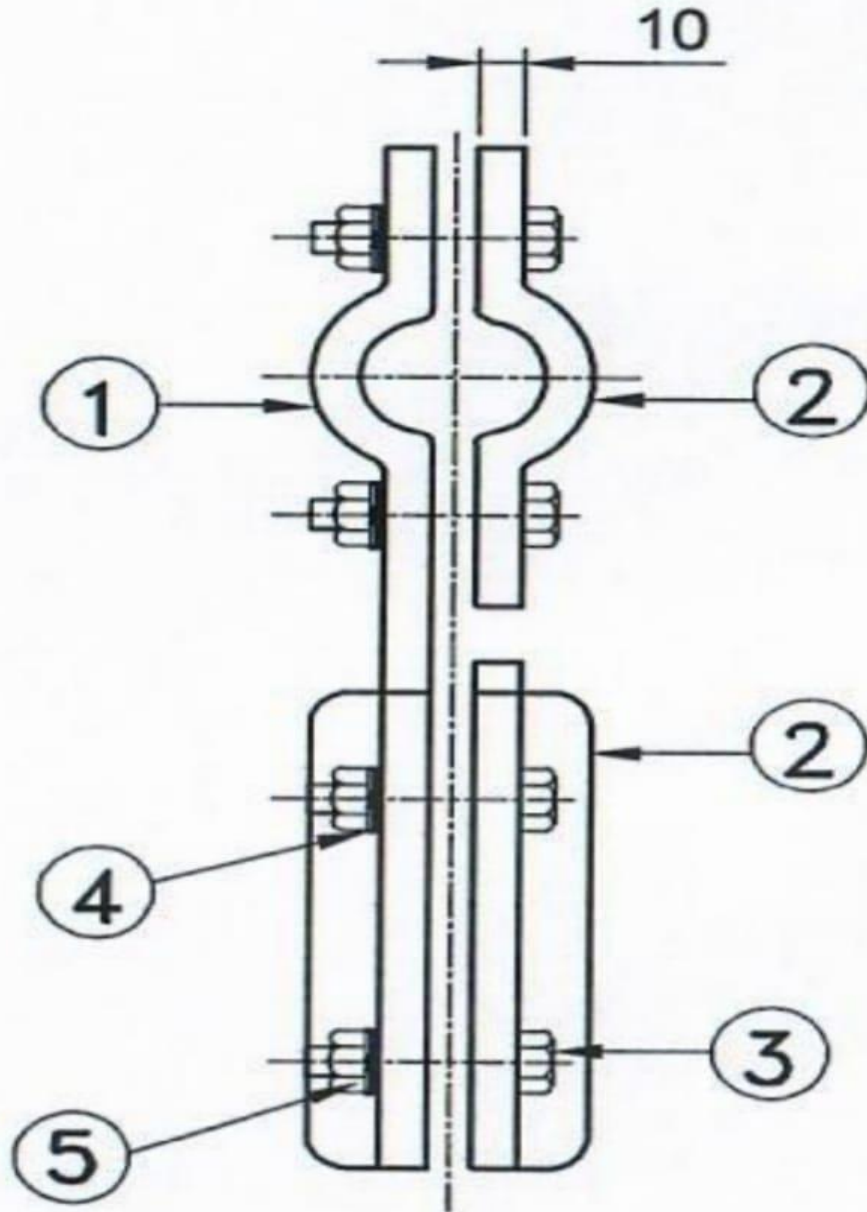

Initiator	<i>Suryakanta Mohanty</i>	HOD (Engineering)	<i>Sanku P.D.</i>
-----------	---------------------------	-------------------	-------------------

 TPNODL TP NORTHERN ODISHA DISTRIBUTION LIMITED <small>(A Tata Power and Odisha Government Joint Venture)</small>	TP NORTHERN ODISHA DISTRIBUTION LIMITED		
	TECHNICAL SPECIFICATIONS		
Doc. Title	TECHNICAL SPECIFICATION FOR 33 KV T-CONNECTOR		
Doc. No:	ENG-HV-032	Eff. Date: 20.12.2021	
Rev No:	00	Page 5 of 12	
Prepared by:	Reviewed by:	Approved by:	Issued by:

6.0 NAME PLATE & MAKING:

Name of Manufacturer, Size to be engraved on all the T-Connectors.

The packing of connectors shall have following details:

- a) Name of Manufacturer
- b) PO no. with date
- c) Month & year of manufacture
- d) PROPERTY OF TPNODL
- e) Item Description
- f) Material code

7.0 TESTS:

7.1 Type test:



- i) Tensile test
- ii) Resistance test
- iii) Temperature rise test
- iv) Short-time current test
- v) Dimensional check
- vi) Galvanizing test
- vii) Climatic ageing test

7.2 Acceptance Test:

- i) Tensile test
- ii) Resistance test
- iii) Dimensional check
- iv) Galvanizing test

7.3 Routine Test:

- i) Visual Inspection.
- ii) Dimensional check.

Initiator		HOD (Engineering)	
-----------	---	-------------------	---

 TPNODL TP NORTHERN ODISHA DISTRIBUTION LIMITED <small>(A Tata Power and Odisha Government Joint Venture)</small>	TP NORTHERN ODISHA DISTRIBUTION LIMITED		
	TECHNICAL SPECIFICATIONS		
Doc. Title	TECHNICAL SPECIFICATION FOR 33 KV T-CONNECTOR		
Doc. No:	ENG-HV-032	Eff. Date: 20.12.2021	
Rev No:	00	Page 6 of 12	
Prepared by:	Reviewed by:	Approved by:	Issued by:

iii) Conductivity test

8.0 TYPE TEST CERTIFICATES:

The bidder shall furnish the type test certificates and result for the tests as mentioned above as per corresponding standards. All the tests shall be conducted at CPRI / ERDA / UL Accredited Labs as per the relevant standards.

Type test should have been conducted in certified Test Laboratories during the period not exceeding 5 years from the date of opening the bid. In the event of any discrepancy in the test reports, i.e., any test report not acceptable or any/all type tests (including additional type tests, if any) not carried out, same shall be carried out without any cost implication to the TPNODL.

9.0 PRE-DESPATCH INSPECTION:



9.1 The Material shall be subject to inspection by a duly authorized representative of the TPNODL. Inspection may be made at any stage of manufacture at the discretion of TPNODL and the equipment, if found unsatisfactory as to workmanship or material, the same is liable to rejection. Bidder shall grant free access to the places of manufacture to TPNODL's representatives at all times when the work is in progress. Inspection by TPNODL or its authorized representatives shall not relieve the bidder of his obligation of furnishing equipment in accordance with the specifications. Material shall be dispatched after specific MDCC (Material Dispatch Clearance Certificate) is issued by TPNODL.

Following documents shall be sent along with material

- a. Test reports
- b. MDCC issued by TPNODL
- c. Invoice in duplicate
- d. Packing list
- e. Drawings & catalogue
- f. Guarantee / Warrantee card
- g. Delivery Challan
- h. Other Documents (as applicable).

9.2) In respect of raw material used for T- Connector, bidder shall use materials manufactured/supplied by standard manufacturers and furnish the manufacturers' test certificate as well as the proof of purchase from these manufacturers (excise gate pass) for information of the TPNODL. The bidder shall furnish following documents along with their offer in respect of the raw materials:

- a. Invoice of bidder

Initiator		HOD (Engineering)	
-----------	---	-------------------	---

 TPNODL TP NORTHERN ODISHA DISTRIBUTION LIMITED <small>(A Tata Power and Odisha Government Joint Venture)</small>	TP NORTHERN ODISHA DISTRIBUTION LIMITED		
	TECHNICAL SPECIFICATIONS		
Doc. Title	TECHNICAL SPECIFICATION FOR 33 KV T-CONNECTOR		
Doc. No:	ENG-HV-032	Eff. Date: 20.12.2021	
Rev No:	00	Page 7 of 12	
Prepared by:	Reviewed by:	Approved by:	Issued by:

- b. Mill's certificate
- c. Packing List
- d. Bill of landing
- e. Bill of entry certificate by custom

10.0 INSPECTION AFTER RECEIPT AT STORES:

The material received at TPNODL store shall be inspected for acceptance and shall be liable for rejection, if found different from the reports of the pre-dispatch inspection and one copy of the report shall be sent to Plant Engineering department.

11.0 GUARANTEE



Bidder shall stand guarantee towards design, materials, workmanship & quality of process / manufacturing of items under this contract for due and intended performance of the same, as an integrated product delivered under this contract. In the event any defect is found by TPNODL, up to a period of at least 12 months from the date of commissioning or 24 months from the date of last supplies made under the contract whichever is later, (the time scale of 12/24 months could be enhanced subject to mutual agreements). Bidder shall be liable to undertake to replace/rectify such defects at its own costs, within mutually agreed time frame, and to the entire satisfaction of TPNODL, failing which TPNODL will be at liberty to get it replaced/rectified at Bidder's risks and costs and recover all such expenses plus the TPNODL's own charges (@ 20% of expenses incurred), from the Bidder or from the "Security cum Performance Deposit" as the case may be. Bidder shall further be responsible for 'free replacement' for another period of THREE years from the end of the guarantee period for any 'Latest Defects' if noticed and reported by TPNODL.

12.0 PACKING:

Bidder shall ensure that the material covered under this specification shall be prepared for rail/road transport (local equipment) and be packed in such a manner as to protect the equipment from damage in transit.

13.0 TENDER SAMPLE:

Bidders should submit samples of their quoted items at TPNODL central Store, Balasore and furnished store receipt copy along with bid documents for verification.

Initiator		HOD (Engineering)	
-----------	---	-------------------	---

 TPNODL TP NORTHERN ODISHA DISTRIBUTION LIMITED <small>(A Tata Power and Odisha Government Joint Venture)</small>	TP NORTHERN ODISHA DISTRIBUTION LIMITED		
	TECHNICAL SPECIFICATIONS		
Doc. Title	TECHNICAL SPECIFICATION FOR 33 KV T-CONNECTOR		
Doc. No:	ENG-HV-032	Eff. Date: 20.12.2021	
Rev No:	00	Page 8 of 12	
Prepared by:	Reviewed by:	Approved by:	Issued by:

14.0 QUALITY CONTROL:

The bidder shall submit with the offer Quality assurance plan indicating the various stages of inspection, the tests and checks which will be carried out on the material of construction, components during manufacture and bought out items and fully assembled component and equipment after finishing. As part of the plan, a schedule for stage and final inspection within the parameters of the delivery schedule shall be furnished.

TPNODL reserves the sole rights for the type test of random sample from the lot and in case of any discrepancy or deviation from the Type test certificates submitted along with the bid, the complete Lot shall be rejected.

TPNODL's engineer or its nominated representative shall have free access to the bidder's works to carry out inspections.

15.0 MINIMUM TESTING FACILITIES:

Bidder shall Bidder save adequate in-house testing facilities for carrying out all routine test & acceptance tests as per relevant International / Indian standards.

16.0 MANUFACTURING ACTIVITIES:

The successful bidder will have to submit the bar chart for various manufacturing activities clearly elaborating each stage, with quantity. This bar chart should be in line with the Quality assurance plan submitted with the offer. This bar chart will have to be submitted within 15 days from the release of the order.



17.0 SPARES, ACCESSORIES AND TOOLS:

Not Required.

18.0 DRAWINGS AND DOCUMENTS:

Following drawings & Documents shall be prepared based on TPNODL specifications and statutory requirements and shall be submitted with the bid:

- a) Completely filled-in GTP.
- b) General arrangement drawing T-Connector.

Initiator		HOD (Engineering)	
-----------	---	-------------------	---

 TPNODL TP NORTHERN ODISHA DISTRIBUTION LIMITED <small>(A Tata Power and Odisha Government Joint Venture)</small>	TP NORTHERN ODISHA DISTRIBUTION LIMITED		
	TECHNICAL SPECIFICATIONS		
Doc. Title	TECHNICAL SPECIFICATION FOR 33 KV T-CONNECTOR		
Doc. No:	ENG-HV-032	Eff. Date: 20.12.2021	
Rev No:	00	Page 9 of 12	
Prepared by:	Reviewed by:	Approved by:	Issued by:

- c) General description of equipment and all components including brochures.
- d) Bill of material.
- e) Experience List
- f) Type test certificates

Drawings/documents to be submitted after the award of the contract:

Sr. No.	Description	For Approval	For Review Information	Final Submission
1	Technical parameters	✓		✓
2	General Arrangement Drawings	✓		✓
3	Installation Instruction		✓	✓
4	Mounting and fixing drawing	✓	✓	✓
5	QA & QC Plan	✓	✓	✓
6	Test Certificates	✓	✓	✓

All the documents & drawings shall be in English language.

After receipt of the order, the successful bidder shall be required to furnish soft copies of all relevant drawings and GTP for TPNODL approval.

19.0 GUARANTEED TECHNICAL PARTICULARS:

S. No	Description	To be furnished by bidder
1.	Suitable size of main conductor	
2.	Suitable size of branch conductor	
3.	Rated Voltage	

Initiator	<i>Suryakanta Mohanty</i>	HOD (Engineering)	<i>Sanku P.D.</i>
-----------	---------------------------	-------------------	-------------------

 TPNODL TP NORTHERN ODISHA DISTRIBUTION LIMITED <small>(A Tata Power and Odisha Government Joint Venture)</small>	TP NORTHERN ODISHA DISTRIBUTION LIMITED		
	TECHNICAL SPECIFICATIONS		
Doc. Title	TECHNICAL SPECIFICATION FOR 33 KV T-CONNECTOR		
Doc. No:	ENG-HV-032	Eff. Date: 20.12.2021	
Rev No:	00	Page 10 of 12	
Prepared by:	Reviewed by:	Approved by:	Issued by:

4.	System Frequency	
5.	Material Composition	
6.	Pressure surfaces	
8.	Hot dip galvanizing of Bolt	Yes/No
9.	Is Bolt 8.8 grade	Yes/No
13.	No. of Bolts	
14	Size of Bolts	
15	Weight of T Connector	
16	Size of T- Connector (LXW)mm	
17	Thickness of T-Connector	

20.0 SCHEDULE OF DEVIATIONS:

(TO BE ENCLOSED WITH TECHNICAL BID)

All deviations from this specification shall be set out by the Bidders, clause by Clause in this schedule. Unless specifically mentioned in this Schedule, the tender shall be deemed to confirm the purchaser's specifications.

Sr. No.	Clause No.	Details of deviation with justifications

We confirm that there are no deviations apart from those detailed above.

Signature of Bidder:

Name of the Company:

Date:'

Office Seal:

Initiator	<i>Suryakanta Mohanty</i>	HOD (Engineering)	<i>Sanku P.D.</i>
-----------	---------------------------	-------------------	-------------------

TPNODL TP NORTHERN ODISHA DISTRIBUTION LIMITED <small>(A Tata Power and Odisha Government Joint Venture)</small>	TP NORTHERN ODISHA DISTRIBUTION LIMITED		
	TECHNICAL SPECIFICATIONS		
Doc. Title	TECHNICAL SPECIFICATION FOR 33 KV T-CONNECTOR		
Doc. No:	ENG-HV-032	Eff. Date: 20.12.2021	
Rev No:	00	Page 11 of 12	
Prepared by:	Reviewed by:	Approved by:	Issued by:

DRAWING: T-CONNECTOR

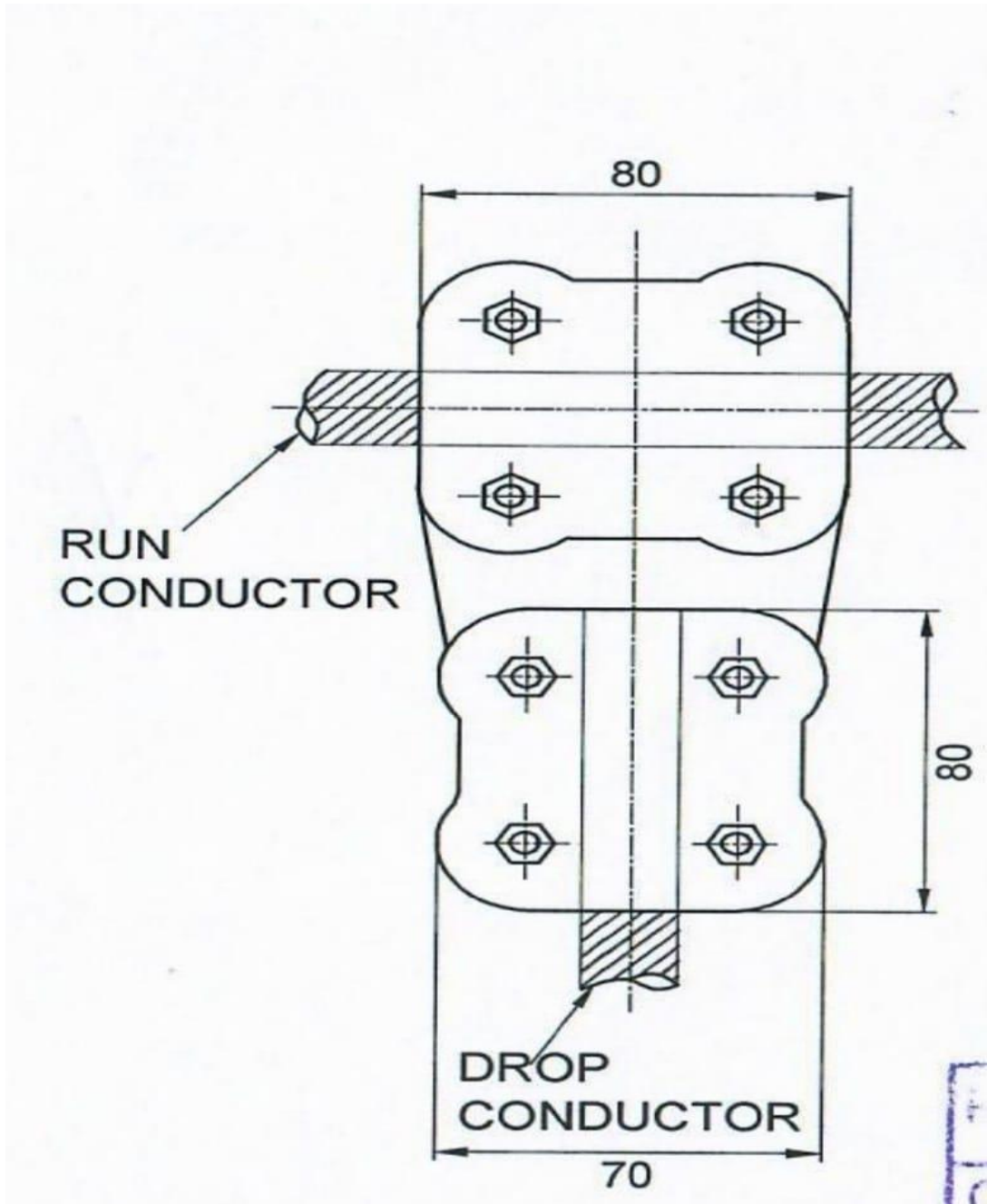

Initiator	<i>Suryakanta Mohanty</i>	HOD (Engineering)	<i>Sanku P.D.</i>
-----------	---------------------------	-------------------	-------------------

 TPNODL TP NORTHERN ODISHA DISTRIBUTION LIMITED <small>(A Tata Power and Odisha Government Joint Venture)</small>	TP NORTHERN ODISHA DISTRIBUTION LIMITED		
	TECHNICAL SPECIFICATIONS		
Doc. Title	TECHNICAL SPECIFICATION FOR 33 KV T-CONNECTOR		
Doc. No:	ENG-HV-032	Eff. Date: 20.12.2021	
Rev No:	00	Page 12 of 12	
Prepared by:	Reviewed by:	Approved by:	Issued by:

Initiator	<i>Suryakanta Mohanty</i>	HOD (Engineering)	<i>Sanku P.D.</i>
-----------	---------------------------	-------------------	-------------------

TPNODL TP NORTHERN ODISHA DISTRIBUTION LIMITED <small>(A Tata Power and Odisha Government Joint Venture)</small>	TP NORTHERN ODISHA DISTRIBUTION LIMITED		
	TECHNICAL SPECIFICATIONS		
Doc. Title	SPECIFICATION FOR 33kV LINE BIRD FLAPPER/DIVERTER		
Doc. No	ENG-EHV-017	Eff. Date: 13.12.2021	
Rev No.	00	Page 1 of 11	
Prepared by: Engineering Department	Reviewed by:	Approved by:	Issued by:

CONTENTS
1. SCOPE
2. APPLICABLE STANDARDS
3. CLIMATIC CONDITIONS OF THE INSTALLATION
4. GENERAL TECHNICAL REQUIREMENT
5. MARKING
6. TESTS
7. TYPE TEST CERTIFICATES
8. PRE-DISPATCH INSPECTION
9. INSPECTION AFTER RECEIPT AT STORES
10. GUARANTEE
11. PACKING AND TRANSPORT
12. TENDER SAMPLE
13. TRAINING
14. QUALITY CONTROL
15. MINIMUM TESTING FACILITIES
16. MANUFACTURING ACTIVITIES
17. SPARES, ACCESSORIES, AND TOOLS
18. DRAWINGS AND DOCUMENTS
19. GUARANTEED TECHNICAL PARTICULARS
20. SCHEDULE OF DEVIATIONS

Initiator	<i>Suryakanta Mohanty</i>	HOD (Engineering)	<i>Sanku P.D.</i>
-----------	---------------------------	-------------------	-------------------

TPNODL TP NORTHERN ODISHA DISTRIBUTION LIMITED <small>(A Tata Power and Odisha Government Joint Venture)</small>		TP NORTHERN ODISHA DISTRIBUTION LIMITED	
TECHNICAL SPECIFICATIONS			
Doc. Title		SPECIFICATION FOR 33kV LINE BIRD FLAPPER/DIVERTER	
Doc. No	ENG-EHV-017	Eff. Date: 13.12.2021	
Rev No.	00	Page 2 of 11	
Prepared by: Engineering Department	Reviewed by:	Approved by:	Issued by:

1. SCOPE

The electrocution and collision of Great Indian Bustard (GIB) and other birds with the overhead power distribution lines is one of the major causes of death of these birds. Great Indian Bustard, is one of the flagship bird species of India and State bird of Rajasthan, which is an endangered/near extinct species. Bird Flight Diverter, identified as one of the measures to avoid the chances of collision of birds with high voltage distribution lines, and shall be placed in identified stretches as per the guidelines of the Forest Authority.

Bird Flight Diverter (BFD) designs available with different manufacturers in the market are not similar and it becomes difficult for the utilities to procure suitable diverters for their requirement meeting environmental conditions. Moreover, the size, color, operating temperature, grip strength & other construction features of Bird Flight Diverter, the installation and testing are some of the important features/parameters, which needs to be standardized. Keeping in mind difficulty being faced by the utilities, there is need for standardization of specifications of Bird Flight Diverter so that similar type of bird diverters are installed on the power transmission & distribution lines across the country.

The specification broadly covers general technical requirement, major design parameters, and requirement of certification, type tests & test procedures and installation guide of Bird Flight Diverter etc.

2. APPLICABLE STANDARDS:

3. CLIMATIC CONDITIONS:

a)	Maximum Ambient Temperature	50 °C
b)	Maximum Daily Average Ambient Temperature	40 °C
c)	Minimum Ambient Temperature	2 °C
d)	Maximum Humidity	99.7 %
e)	Minimum Humidity	15 %
f)	Average Annual Rainfall	1800 mm
g)	Average Wind Speed prevailing in the area	200 km/hr.
h)	Average Thunderstorms prevailing in the area	70 days per annum
i)	Average dust storms prevailing in the area	20 days per annum
j)	Average number of rainy days per annum	160
k)	Maximum Altitude above sea level	1200 m

Initiator	<i>Suryakanta Mohanty</i>	HOD (Engineering)	<i>Sanku P.D.</i>
-----------	---------------------------	-------------------	-------------------

TPNODL <small>TP NORTHERN ODISHA DISTRIBUTION LIMITED</small> <small>(A Tata Power and Odisha Government Joint Venture)</small>		TP NORTHERN ODISHA DISTRIBUTION LIMITED	
TECHNICAL SPECIFICATIONS			
Doc. Title		SPECIFICATION FOR 33kV LINE BIRD FLAPPER/DIVERTER	
Doc. No	ENG-EHV-017	Eff. Date: 13.12.2021	
Rev No.	00	Page 3 of 11	
Prepared by: Engineering Department	Reviewed by:	Approved by:	Issued by:

I)	Seismic Level	0.24g to 0.48g
----	---------------	----------------

Note: The atmosphere across coastal divisions of TPNODL is very saline, laden with salt, acid and dust suspended during dry months and subjected to fog in cold months.

4. GENERAL TECHNICAL REQUIREMENTS:

Sl.No.	Desired Constructions
4.1	Bird Flight Diverter must be dynamic type and shall consist of warning disc and associated clamps & connectors. These diverters may or may not have solar powered LED. The dynamic solar powered LED type Bird Flight Diverter shall be preferred in areas where foggy/dusty weather persists or intensity of light is low or the sections of the lines lying in the route of migratory birds. The requirement of solar powered LED may be decided by the utility.
4.2	Bird Flight Diverter shall be suitable for efficient working and shall retain good physical characteristics under all weather conditions.
4.3	Bird Flight Diverter (BFD) shall be designed for expected service life of at least 15 years.
4.4	BFD shall be suitable for installation on live line.
4.5	For visibility of Bird Flight Diverter, warning disc shall be provided. Warning disc shall
(a)	Have glow in dark feature. Glow in dark shall remain activated for at least 12 hours after exposure to sun light. If Glow in dark stickers are used, the same shall be laminated and suitable for all weather conditions.
(b)	Have contrasting colored (combination of any two colors from Red, Yellow, Orange, and White) retro-reflective surface with Sun and Moon light reflectors on both faces. Since, warning disc is to be designed to rotate, the color change, while revolving, shall provide significant for warning.
(c)	Swing, sway and rotate easily.
(d)	Be resistant to all weather conditions.
(e)	Be aerodynamically stable so that diverter faces minimum amount of drag force which provide swing and rotation effect under medium/strong wind speed.
(f)	Be made of UV stabilized plastic. Bearing swivel shall be made of stainless steel and should allow free spinning in minimum wind speed of 2 km/hour.
(g)	Have diameter not less than 150 mm for circular disc. If warning disc is quadrilateral or trapezoid or of any other shape, then shortest arm length shall not be less than 90 mm and total surface area of warning disc should not be less than 15000 mm ² (including air vents).
(h)	have thickness of not less than 3 mm.

Initiator	<i>Suryakanta Mohanty</i>	HOD (Engineering)	<i>Sanku P.D.</i>
-----------	---------------------------	-------------------	-------------------

TPNODL TP NORTHERN ODISHA DISTRIBUTION LIMITED <small>(A Tata Power and Odisha Government Joint Venture)</small>		TP NORTHERN ODISHA DISTRIBUTION LIMITED	
TECHNICAL SPECIFICATIONS			
Doc. Title		SPECIFICATION FOR 33kV LINE BIRD FLAPPER/DIVERTER	
Doc. No	ENG-EHV-017	Eff. Date: 13.12.2021	
Rev No.	00	Page 4 of 11	
Prepared by: Engineering Department	Reviewed by:	Approved by:	Issued by:

(i)	Not have less than 3500 mm ² reflective area on each face of warning disc. Glow in Dark area also should not be less than 3500 mm ²
4.6	Weight of Bird Flight diverter shall not be more than 500 gm. LED type bird flight diverter should not weigh more than 800 gm.
4.7	Length of bird diverter, from connection point to end, should not be more than 350 mm
4.8	Clamp & Hardware: The warning disc shall be suitable for hanging on conductor by means of clamp & hardware. Design details are as follows:
(a)	The clamp for holding conductor wire shall be spring type and shall be made of UV stabilized engineered composite plastic (polymer) or metal and shall be suitable for live line installation by hot stick or drone.
(b)	All metal hardware used in Bird Flight Diverter including bearing must be made of corrosion free material.
(c)	All plastic (polymer) parts must be UV stabilized.
(d)	Clamp must be suitable for gripping the conductor wire strongly, otherwise due to Aeolian vibrations/high wind speed diverters may shift and move from its original position and get collected at mid span (lowest sagging point). Rubber/polyurethane lining shall be used in gripping area of clamp as per requirement of conductor type.
(e)	More than 50% of clamp gripping area shall be in contact with Conductor wire.
(f)	Clamp shall be free from sharp ends or edges, abrasions, projections, grit or materials, and shall not cause chafing or damage to the conductor wire during fitting or during continued operation.
(g)	Parts of the clamp touching conductor must be able to withstand temperature range from -15 °C to + 85 °C for conventional conductors. In case of installation on HTLS conductor, maximum operating temperature under emergency loading condition shall be specified by the utility.
(h)	The clamp must be able to bear pulling load of at least 30 kg and it is to be tested on Universal Testing Machine by a NABL accredited laboratory.
(i)	Grip retaining strength: The clamp shall have smooth and permanent grip to keep the Bird Flight Diverter in its original position on the conductor without damaging the strands or causing premature fatigue failure of the conductor due to clamping pressure. The clamp should not slip beyond permissible limit as specified in test procedure in Annexure, when pulled by a force of 20 Kg in the direction parallel to conductor.
(j)	In case of metallic bird diverters, the parts of clamp, touching conductor must be made of material, which is bad conductor of electricity.
4.9	For solar powered LED type diverter, following additional requirement shall be fulfilled:
(a)	LED shall be of Orange color with adequate light intensity so that it is clearly visible to birds from a distance even during foggy/dusty weather/under low intensity of light.
(b)	Battery shall be guaranteed for service life of 5 years and shall be suitable for at least 100 hrs. of flashing operation by single charge.
(c)	An automatic power cut-off electronics circuit shall be provided to improve battery life so that during day time (due to high intensity of light from sun), the circuit gets cut off & stops flashing and the circuit switches

Initiator	<i>Suryakanta Mohanty</i>	HOD (Engineering)	<i>Sanku P.D.</i>
-----------	---------------------------	-------------------	-------------------

TPNODL <small>TP NORTHERN ODISHA DISTRIBUTION LIMITED</small> <small>(A Tata Power and Odisha Government Joint Venture)</small>		TP NORTHERN ODISHA DISTRIBUTION LIMITED	
		TECHNICAL SPECIFICATIONS	
Doc. Title		SPECIFICATION FOR 33kV LINE BIRD FLAPPER/DIVERTER	
Doc. No	ENG-EHV-017	Eff. Date: 13.12.2021	
Rev No.	00	Page 5 of 11	
Prepared by: Engineering Department	Reviewed by:	Approved by:	Issued by:

	on automatically under low intensity light condition.
(d)	Position of solar cell shall be such that it gets sunlight irrespective of direction of the diverter face and the dust & snow does not decrease its efficiency.
5.	MARKING: The unit shall be appropriately marked as " PROPERTY OF TPNODL, BALASORE " and with the name of the vendor and year of manufacturing at suitable location.
6.	TESTS: <ul style="list-style-type: none"> • All routine, acceptance & type tests shall be carried out in accordance with the relevant IS 9921 and relevant IEC. • All routine/acceptance tests shall be witnessed by the TPNODL authorized representative. • All the components and fittings shall also be type tested as per the relevant standards.
6.1	Type Tests: The reports/certificates for following type tests conducted in any NABL or equivalent accredited laboratory shall be submitted to the purchaser. All of the following tests shall be conducted on the same sample. However, No. of Samples for type tests shall be as per relevant standard or procedure specified in Annexure. Type test report shall be valid for 10 years from the date of successful completion of tests. <ul style="list-style-type: none"> (a) Mechanical Strength test <ul style="list-style-type: none"> • Direct Pull Test • Clamp Slip Test/Grip Retaining Strength Test (b) Vibration test (c) Temperature cycle test (d) Heating cycle test (e) Radio Interference Voltage and Visual Corona Test (f) Corrosion Resistance Test: Salt fog (at 5% salt solution) and Humidity test (at 90% Rh) as per procedure in accordance with MIL-STD 810F (method 509.4 and Method 507.4) (g) Ageing tests - solar radiation test & sand and dust test as per procedure in accordance with MIL-STD 810F (Method 505.4 proc II and 510.4 proc I) <p>Note: The Mechanical Strength Tests shall be carried out before and after Ageing Test.</p>
6.2	Acceptance Test: Following acceptance tests shall be carried out on at least 5 samples in presence of the representative of the purchaser: <ul style="list-style-type: none"> a) Visual Examination Test b) Verification of Dimensions h) Mechanical Strength test * <ul style="list-style-type: none"> • Direct Pull Test • Clamp Slip Test/Grip Retaining Strength Test

Initiator	<i>Suryakanta Mohanty</i>	HOD (Engineering)	<i>Sanku P.D.</i>
-----------	---------------------------	-------------------	-------------------

TPNODL <small>TP NORTHERN ODISHA DISTRIBUTION LIMITED</small> <small>(A Tata Power and Odisha Government Joint Venture)</small>		TP NORTHERN ODISHA DISTRIBUTION LIMITED	
		TECHNICAL SPECIFICATIONS	
Doc. Title		SPECIFICATION FOR 33kV LINE BIRD FLAPPER/DIVERTER	
Doc. No	ENG-EHV-017	Eff. Date: 13.12.2021	
Rev No.	00	Page 6 of 11	
Prepared by: Engineering Department	Reviewed by:	Approved by:	Issued by:



	(a) *Only one of the 5 samples shall be subjected to ultimate failing load.
--	---

7. TYPE TEST CERTIFICATES:
<p>The bidder shall furnish the type test certificates of the cable for the tests as mentioned as above as per the corresponding standards. All the tests shall be conducted by CPRI/ERDA as per the relevant standards. Type test should have been conducted in certified Test Laboratories during the period not exceeding 5 years from the date of opening the bid. In the event of any discrepancy in the test reports i.e., any test report not acceptable or any/all type tests (including additional type tests, if any) not carried out, same shall be carried out without any cost implication to TPNODL.</p>

8. PRE-DISPATCH INSPECTION:
<p>The equipment shall be subject to inspection by a duly authorized representative of the TPNODL. Inspection may be made at any stage of manufacture at the discretion of the purchaser and the equipment, if found unsatisfactory as to workmanship or material, the same is liable to rejection. Bidder shall grant free access to the places of manufacture to TPNODL's representatives at all times when the work is in progress. Inspection by the TPNODL or its authorized representatives shall not relieve the bidder of his obligation of furnishing equipment in accordance with the specifications. Material shall be dispatched after specific MDCC (Material Dispatch Clearance Certificate) is issued by TPNODL.</p> <p>Following documents shall be sent along with material</p> <ol style="list-style-type: none"> a) Test reports b) MDCC issued by TPNODL c) Invoice in duplicate d) Packing list e) Drawings & catalogue f) Guarantee / Warrantee card g) Delivery Challan h) h) Other Documents (as applicable).

9. INSPECTION AFTER RECEIPT AT STORE:
<p>The material received at TPNODL store will be inspected for acceptance and shall be liable for rejection, if found different from the reports of the pre-dispatch inspection and one copy of the report shall be sent to Engineering & Contracts department.</p>

10. GUARANTEE:
<p>Bidder shall stand guarantee towards design, materials, workmanship & quality of process/ manufacturing of items under this contract for due and intended performance of the same, as an integrated product delivered under this contract. In the event any defect is found by the Purchaser up to a period of at least 18 months from the date of commissioning or 24 months from the date of last supplies made under the contract whichever is later, (the time scale of 18/24 months could be enhanced subject to mutual agreements). Bidder shall be liable to undertake to replace/rectify such defects at its own costs, within mutually agreed time frame, and to the entire</p>

Initiator		HOD (Engineering)	
-----------	---	-------------------	---

TPNODL <small>TP NORTHERN ODISHA DISTRIBUTION LIMITED</small> <small>(A Tata Power and Odisha Government Joint Venture)</small>		TP NORTHERN ODISHA DISTRIBUTION LIMITED	
TECHNICAL SPECIFICATIONS			
Doc. Title		SPECIFICATION FOR 33kV LINE BIRD FLAPPER/DIVERTER	
Doc. No	ENG-EHV-017	Eff. Date: 13.12.2021	
Rev No.	00	Page 7 of 11	
Prepared by: Engineering Department	Reviewed by:	Approved by:	Issued by:

satisfaction of the Purchaser, failing which the Purchaser will be at liberty to get it replaced/rectified at Bidder's risks and costs and recover all such expenses plus the Purchaser's own charges (@ 20% of expenses incurred), from the Bidder or from the "Security cum Performance Deposit" as the case may be. Bidder shall further be responsible for 'free replacement' for another period of THREE years from the end of the guarantee period for any 'Latent Defects' if noticed and reported by the Purchaser.

11. PACKING AND TRANSPORT:

Bidder shall ensure that all the equipment covered under this specification shall be prepared for rail/road transport in a manner so as to protect the equipment from damage in transit.

Note: One use plastic not to be used for packing of the material.

12. TENDER SAMPLE:

One no. Sample to be submitted during technical bid submission.

13. TRAINING :

The bidder shall arrange to provide training of our staff if required for installation & commissioning or maintenance etc.

14. QUALITY CONTROL:

The bidder shall submit with the offer Quality assurance plan indicating the various stages of inspection, the tests and checks which will be carried out on the material of construction, components during manufacture and bought out items and fully assembled component and equipment after finishing. As part of the plan, a schedule for stage and final inspection within the parameters of the delivery schedule shall be furnished. The Purchaser's engineer or its nominated representative shall have free access to the manufacturer's/sub-supplier's works to carry out inspections.

15. MINIMUM TESTING FACILITIES:

Bidder shall have adequate in-house testing facilities for carrying out all routine tests & acceptance tests as per relevant International / Indian standards.

16. MANUFACTURING ACTIVITIES

The successful bidder will have to submit the bar chart for various manufacturing activities clearly elaborating each stage, with quantity. This bar chart should be in line with the Quality assurance plan submitted with the offer. This bar chart will have to be submitted within 15 days from the release of the order.

17. SPARES, ACCESSORIES & TOOLS:

Bidders shall provide a list of recommended spares with quantity and unit prices for 3 years of operation after Commissioning. The bidder shall provide a list of complete set of accessories and tools required for erection & Maintenance along with the installation procedure.

18. DRAWINGS AND DOCUMENTS:

Initiator	<i>Suryakanta Mohanty</i>	HOD (Engineering)	<i>Sanku P.D.</i>
-----------	---------------------------	-------------------	-------------------

TPNODL <small>TP NORTHERN ODISHA DISTRIBUTION LIMITED</small> <small>(A Tata Power and Odisha Government Joint Venture)</small>		TP NORTHERN ODISHA DISTRIBUTION LIMITED	
TECHNICAL SPECIFICATIONS			
Doc. Title		SPECIFICATION FOR 33kV LINE BIRD FLAPPER/DIVERTER	
Doc. No	ENG-EHV-017	Eff. Date: 13.12.2021	
Rev No.	00	Page 8 of 11	
Prepared by: Engineering Department	Reviewed by:	Approved by:	Issued by:

Following drawings and documents shall be prepared based on TPNODL specifications and statutory requirements and shall be submitted with the bid:

- Completely filled in Technical Particulars and compliance to each clause of the specification General Technical Requirements to Additional Details.
- Description of the equipment and all components including brochures.
- General Drawing arrangement
- Experience Certificate and list.
- Type test certificates.

Drawings / documents to be submitted after the award of the contract are as under:

After the contract, four (4) copies of the drawings, drawn to scale, describing the equipment in detail shall be forwarded for approval and shall subsequently provide four (4) complete sets of final drawings, one of which shall be auto positive suitable for reproduction, before the dispatch of the equipment. Soft copy (Compact Disk CD) of all the drawing, test certificates shall be submitted after the final approval of the same to the purchaser.

Following Drawings/Documents shall be submitted after the award of the contract:
 Drawings/documents to be submitted after the award of the contract:

S. No	Description	For Approval	For Review Information	Final Submission
1	Technical Parameters	√		√
2	General Arrangement drawings	√		√
3	Manual/Catalogues/drawings		√	
4	Installation Instructions (if any)		√	√
5	QA & QC Plan	√	√	√
6	Routine, Acceptance & Type Test Certificates	√	√	√

All the documents & drawings shall be in English language.

19. GUARANTEED TECHNICAL PARTICULARS

Sl. No.	Descriptions	Desired Value	To be furnished by Bidder
1	Warning Disc	Dynamic Type	
1.1	Performance	Good Physical characteristics under all-weather condition	
1.2	Expected Service Life	15 Years	
1.3	Installation feasibility	Suitable for installation on Live Line	
	WARNING DISC		
2	Type of Disc	Glow in Dark Feature. Glow in dark shall remain activated for at least 12 hours after exposure to Sun light. If Glow in dark Stickers are used, the	

Initiator	<i>Suryakanta Mohanty</i>	HOD (Engineering)	<i>Sanku P.D.</i>
-----------	---------------------------	-------------------	-------------------

TPNODL <small>TP NORTHERN ODISHA DISTRIBUTION LIMITED</small> <small>(A Tata Power and Odisha Government Joint Venture)</small>		TP NORTHERN ODISHA DISTRIBUTION LIMITED	
TECHNICAL SPECIFICATIONS			
Doc. Title		SPECIFICATION FOR 33kV LINE BIRD FLAPPER/DIVERTER	
Doc. No	ENG-EHV-017	Eff. Date: 13.12.2021	
Rev No.	00	Page 9 of 11	
Prepared by: Engineering Department	Reviewed by:	Approved by:	Issued by:



		same shall be laminated and suitable for all weather Conditions. Have Contrasting Colored (Combination of any two colors from Red, Yellow, Orange, White) retro-reflective surface with Sun and Moon Light reflectors on both faces. Since, Warning disc is to be designed to rotate, the color change, while revolving, shall provide significant Forewarning.	
2.1	Movement	Swing, sway and Rotate	
2.2	Weather effect	Resistant to all weather condition	
2.3	Shape	Aerodynamically stable	
2.4	Type of Material	UV stabilized Plastic	
2.5	Bearing	Shall be of stainless steel and should allow free spinning in minimum wind speed of 2km/hr	
2.6	Size of Disc	Diameter not less than 150 mm for Circular disc. If warning disc is quadrilateral or trapezoid or of any other shape, then shortest arm length shall not be less than 90 mm.	
2.7	Total Surface Area	Total Surface Area not be less than 15000 sq.mm (including air Vents)	
2.8	Thickness	Thickness not less than 3 mm	
2.9	Area of Glow in Dark	Glow in Dark Area not less than 3500 sq.mm	
2.10	Weight	Not more than 500 gms	
2.11	Length	Not more than 430 mm	
3	Clamp & Hardware		
3.1	Clamps & Hardware	UV Stabilized engineered composite plastic (polymer)	
3.2		All metal hardware including bearing must be made of corrosion free material	
3.3		All plastic (Polymer) part must be UV stabilized	
3.4		Clamps must be suitable for gripping the conductor strongly	
3.5		More than 50% of clamp gripping area shall be in contact Conductor	
3.6		Clamp must be free from sharp ends or edges, abrasions, projections, grit or materials and shall not cause chafing or damage to the Conductor during fitting or during continued operation	
3.7		Parts of the clamp touching	

Initiator	<i>Suryakanta Mohanty</i>	HOD (Engineering)	<i>Sanku P.D.</i>
-----------	---------------------------	-------------------	-------------------

TPNODL <small>TP NORTHERN ODISHA DISTRIBUTION LIMITED</small> <small>(A Tata Power and Odisha Government Joint Venture)</small>		TP NORTHERN ODISHA DISTRIBUTION LIMITED	
TECHNICAL SPECIFICATIONS			
Doc. Title		SPECIFICATION FOR 33kV LINE BIRD FLAPPER/DIVERTER	
Doc. No	ENG-EHV-017	Eff. Date: 13.12.2021	
Rev No.	00	Page 10 of 11	
Prepared by: Engineering Department	Reviewed by:	Approved by:	Issued by:

		conductor must be able to withstand temperature range -15°C to 85° C	
3.8		The clamp must be able to bear pulling load of at least 50 kg and it to be tested on Universal Testing Machine by a NABL accredited laboratory	
3.9		Grip retaining strength	

20. SCHEDULE OF DEVIATIONS			
<u>(TO BE ENCLOSED WITH TECHNICAL BID)</u>			
<p>All deviations from this specification shall be set out by the Bidders, clause by Clause in this schedule. Unless specifically mentioned in this Schedule, the tender shall be deemed to confirm the Purchaser's specifications:</p>			
Sl. No.	Clause No.	Details of deviation with justifications	
<p>We confirm that there are no deviations apart from those mentioned above.</p>			
Seal of the Company	Designation		
	Signature		

Initiator		HOD (Engineering)	
-----------	---	-------------------	---

TPNODL TP NORTHERN ODISHA DISTRIBUTION LIMITED <small>(A Tata Power and Odisha Government Joint Venture)</small>	TP NORTHERN ODISHA DISTRIBUTION LIMITED		
	TECHNICAL SPECIFICATIONS		
Doc. Title	SPECIFICATION FOR 33kV LINE BIRD FLAPPER/DIVERTER		
Doc. No	ENG-EHV-017	Eff. Date: 13.12.2021	
Rev No.	00	Page 11 of 11	
Prepared by: Engineering Department	Reviewed by:	Approved by:	Issued by:

Initiator	<i>Suryakanta Mohanty</i>	HOD (Engineering)	<i>Sanku P.D.</i>
-----------	---------------------------	-------------------	-------------------

TPNODL TP NORTHERN ODISHA DISTRIBUTION LIMITED <small>(A Tata Power and Odisha Government Joint Venture)</small>	TP NORTHERN ODISHA DISTRIBUTION LIMITED		
	TECHNICAL SPECIFICATIONS		
Doc. Title	SPECIFICATION FOR DIFFERENT SIZE OF ALUMINIUM LUGS		
Doc. No	ENG-GEN-008	Eff. Date: 15-11-2021	
Rev No.	00	Page 1 of 12	
Prepared by: Engineering Department	Reviewed by:	Approved by:	Issued by:

CONTENTS

- 1.0 SCOPE**
- 2.0 APPLICABLE STANDARDS**
- 3.0 CLIMATIC CONDITIONS OF THE INSTALLATION**
- 4.0 GENERAL TECHNICAL REQUIREMENTS**
- 5.0 GENERAL CONSTRUCTIONS**
- 6.0 NAME PLATE AND MARKING**
- 7.0 TESTS TPSODL**
- 8.0 TYPE TEST CERTIFICATES**
- 9.0 PRE-DESPATCH INSPECTION**
- 10.0 INSPECTION AFTER RECEIPT AT STORE**
- 11.0 GUARANTEE**
- 12.0 PACKING**
- 13.0 TENDER SAMPLE**
- 14.0 QUALITY CONTROL**
- 15.0 MINIMUM TESTING FACILITIES**
- 16.0 MANUFACTURING ACTIVITIES**
- 17.0 SPARES, ACCESSORIES AND TOOLS**
- 18.0 DRAWING AND DOCUMENTS**
- 19.0 GURANTEED TECHNICAL PARTICULARS**
- 20.0 SCHEDULE OF DEVIATIONS**

Initiator	<i>Suryakanta Mohanty</i>	HOD (Engineering)	<i>Sanku P.D.</i>
-----------	---------------------------	-------------------	-------------------

TPNODL TP NORTHERN ODISHA DISTRIBUTION LIMITED <small>(A Tata Power and Odisha Government Joint Venture)</small>	TP NORTHERN ODISHA DISTRIBUTION LIMITED		
	TECHNICAL SPECIFICATIONS		
Doc. Title	SPECIFICATION FOR LT DEAD END CLAMP		
Doc. No	ENG-LV-006	Eff. Date: 08-11-2021	
Rev No.	00	Page 2 of 12	
Prepared by: Engineering Department	Reviewed by:	Approved by:	Issued by:

1	SCOPE	This specification covers technical requirements of design, manufacturing, Inspection, testing, Supply, transportation and unloading of Aluminum Lugs at TPNODL stores/site. Aluminum Lugs to be used for cable termination purpose.											
2	APPLICABLE STANDARDS	The equipment covered by this specification shall unless otherwise stated, be designed, manufactured and tested in accordance with the latest editions of the following Indian, International Standards and shall conform to the regulations of the local Statutory authorities: IS 8309:1993- Specification for Compression type tubular terminal ends for aluminum conductors of Insulated cables											
3	CLIMATE CONDITIONS OF THE INSTALLATION	<p>The service conditions shall be as follows:</p> <ol style="list-style-type: none"> 1. Maximum altitude above sea level 1,000m 2. Maximum ambient air temperature 50°C 3. Maximum daily average ambient air temperature 35°C 4. Minimum ambient air temperature 0°C 5. Maximum relative humidity 95% 6. Average number of thunderstorm days per annum (isokeraunic level) 70 7. Average number of rainy days per annum 120 8. Average annual rainfall 150cm 9. Earthquakes of an intensity in horizontal direction - equivalent to seismic acceleration of 0.3g 10. Earthquakes of an intensity in vertical direction - equivalent to seismic acceleration of 0.15g (g being acceleration due to gravity) 11 .Wind velocity: 300 km/hr, 200 km/hr and 160 km/hr. <p>Environmentally, some of the regions, where the work will take place includes coastal areas, subject to high relative humidity, which can give rise to condensation. Onshore winds will frequently be salt laden. On occasions, the combination of salt and condensation may create pollution conditions for outdoor insulators. Some places are in heavily industrial polluted areas.</p> <p>Therefore, Outdoor material and equipment shall be designed and protected for use in exposed, heavily polluted, salty, corrosive and humid coastal atmosphere</p> <p>The design of equipment and accessories shall be suitable to withstand seismic forces corresponding to an acceleration of 0.1 g.</p>											
4	GENERAL TECHNICAL REQUIREMENTS	S. No	Item Description	Dimension of Lugs (mm)									
				E(± 0.1)	A(± 0.1)	C(± 0.1)	D(± 0.3)	F(± 0.2)	B	H	G	L(± 0.1)	J
		1	Lugs Al 4 sq.mm XLPE single hole	5.1	2.9	5.5	12	1.2	7	7	6	-	24
		2	Lugs Al 10 sq.mm	5.2	4.4	7.4	10	2.8	9	9	8	-	30

Initiator	<i>Suryakanta Mohanty</i>	HOD (Engineering)	<i>Sanku P.D.</i>
-----------	---------------------------	-------------------	-------------------

TPNODL TP NORTHERN ODISHA DISTRIBUTION LIMITED <small>(A Tata Power and Odisha Government Joint Venture)</small>	TP NORTHERN ODISHA DISTRIBUTION LIMITED										
	TECHNICAL SPECIFICATIONS										
Doc. Title	SPECIFICATION FOR LT DEAD END CLAMP										
Doc. No	ENG-LV-006							Eff. Date: 08-11-2021			
Rev No.	00							Page 3 of 12			
Prepared by: Engineering Department	Reviewed by:				Approved by:				Issued by:		

			XLPE single hole										
	3	Lugs Al 16 sq.mm XLPE single hole	10.2	5.4	8.3	11.4	2.9	13	11	9			37
	4	Lugs Al 25 sq.mm XLPE single hole	8.4	6.8	12	16	5.2	32	10	8	-		57
	5	Lug Al 35 sq.mm for 7/10 SWG Stay wire	6.4	8	10.8	15	2.8	18	11	11	-		47
	6	Lugs Al 50 sq.mm XLPE single hole	10.5	9.8	16	21.5	6.2	42	12	10	-		72
	7	Lug Al 70 sq.mm for 7/8 SWG Stay wire	10.2	11.6	16	22	4.4	26	13	13	-		60
	8	Lugs Al 95 sq.mm XLPE single hole	13	13.2	22	30	8.8	56	15	13	-		95
	9	Lugs Al 120 sq.mm XLPE single hole	13	14.7	23	31.5	8.3	56	20	15	-		104
	10	Lugs Al 150 sq.mm XLPE single hole	13	16.3	21.6	31.2	4.9	60	20	15	-		108
	11	Lugs Al 185 sq.mm XLPE single hole	16.3	18.4	24.0	34.5	5.5	60	20	15	-		108
	12	Lugs Al 240 sq.mm XLPE single hole	13	19.3	27.2	38	7.6	86	22	22	-		144
	13	Lugs Al 1C*300	16.2	21.8	31.2	44.2	7.5	70	25	19	-		130

Initiator	<i>Suryakanta Mohanty</i>	HOD (Engineering)	<i>Sanku P.D.</i>
-----------	---------------------------	-------------------	-------------------

TPNODL TP NORTHERN ODISHA DISTRIBUTION LIMITED <small>(A Tata Power and Odisha Government Joint Venture)</small>	TP NORTHERN ODISHA DISTRIBUTION LIMITED										
	TECHNICAL SPECIFICATIONS										
Doc. Title	SPECIFICATION FOR LT DEAD END CLAMP										
Doc. No	ENG-LV-006							Eff. Date: 08-11-2021			
Rev No.	00							Page 4 of 12			
Prepared by: Engineering Department	Reviewed by:				Approved by:				Issued by:		

			sq.mm XLPE single hole circular										
	14	Lugs Al 4C*300 sq.mm XLPE single hole sector shaped	16.2	23.5	31.2	42	7.5	70	25	19	-	130	
	15	Lugs Al 400 sq.mm XLPE single hole	20.3	26.8	35.5	51.0	8.5	70	25	19	-	130	
	16	Lugs Al 630 sq.mm XLPE single hole	12.7	31.7	44.4	63	12.7	140	25	19	-	200	
	17	Lugs Al 300 sq.mm XLPE double hole	12.7	21.8	30.2	42	8.4	89	25	19	44.4	191.4	
	18	Lugs Al 630 sq.mm XLPE double hole	12.7	31.7	44.4	63	12.7	140	25	19	44.4	244.4	
<p>Tolerances on B, H, G and J are ± 5 percent.</p> <p>Diagram of Single Hole Lugs in below</p>													

Initiator	<i>Suryakanta Mohanty</i>	HOD (Engineering)	<i>Sanku P.D.</i>
-----------	---------------------------	-------------------	-------------------

TPNODL TP NORTHERN ODISHA DISTRIBUTION LIMITED <small>(A Tata Power and Odisha Government Joint Venture)</small>	TP NORTHERN ODISHA DISTRIBUTION LIMITED	
	TECHNICAL SPECIFICATIONS	
Doc. Title	SPECIFICATION FOR LT DEAD END CLAMP	
Doc. No	ENG-LV-006	Eff. Date: 08-11-2021
Rev No.	00	Page 5 of 12
Prepared by: Engineering Department	Reviewed by:	Approved by:

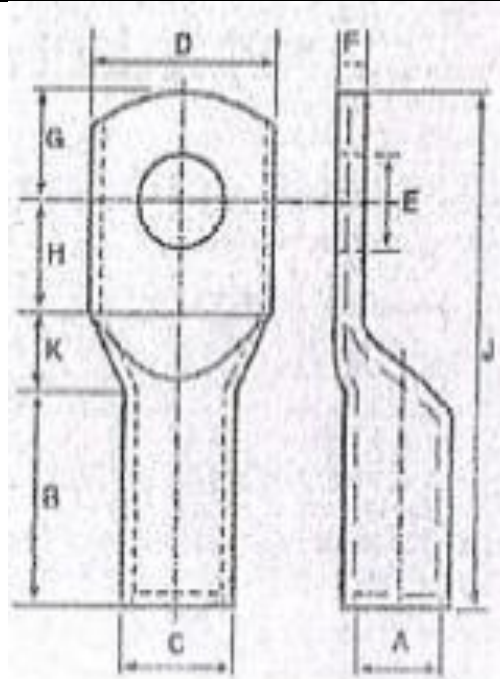
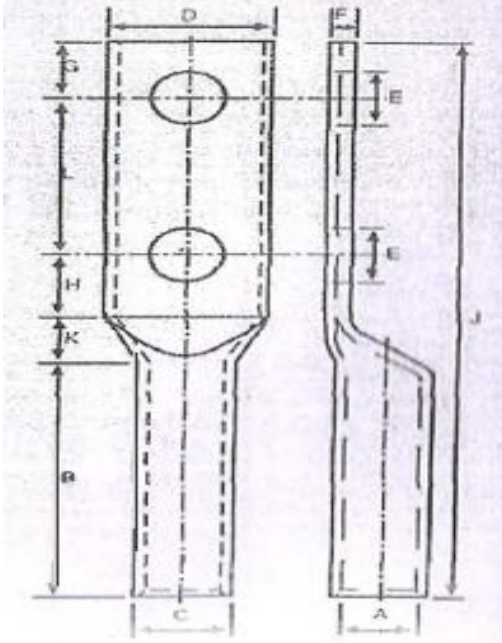

Diagram of Double Hole Lugs in below

Initiator	<i>Suryakanta Mohanty</i>	HOD (Engineering)	<i>Sanku P.D.</i>
-----------	---------------------------	-------------------	-------------------

TPNODL TP NORTHERN ODISHA DISTRIBUTION LIMITED <small>(A Tata Power and Odisha Government Joint Venture)</small>	TP NORTHERN ODISHA DISTRIBUTION LIMITED	
	TECHNICAL SPECIFICATIONS	
Doc. Title	SPECIFICATION FOR LT DEAD END CLAMP	
Doc. No	ENG-LV-006	Eff. Date: 08-11-2021
Rev No.	00	Page 6 of 12
Prepared by: Engineering Department	Reviewed by:	Approved by:

		
5	GENERAL CONSTRUCTIONS	The material of lugs should be Aluminum of 99.9% pure. Material of aluminum shall be as per IS: 5082:1991. Lugs is made of aluminum compression type tubular ends for termination of aluminum conductor of insulated cables. Edges and corners of aluminum lugs shall be free from burrs and sharp edges. Lugs is a connecting device with barrel accommodating respective conductor size of electrical cable and which has a fixing arrangement of termination by means of a bolt fixing or pin insertion in tunnel type terminal blocks and screwing.
6.0	NAME PLATE AND MARKING	N.A.
7.0	TESTS	All routine, acceptance & type tests shall be carried out in accordance with the relevant IS/IEC. All routine & type tests shall be witnessed by the purchaser/his authorized representative. All the components shall also be type tested as per the relevant standards. All dimension of lugs shall meet with the relevant IS 8309:1993, where ever specifically not mentioned.
7.1	TYPE TEST	The following tests shall constitute the type tests and shall be carried out as per IS 8309:1993. 1) Chemical Composition Test. 2) Electrical Conductivity test.
7.2	ROUTINE TEST	The following tests shall be conducted as per IS 8309:1993. Routine test to be done on the random samples (As per IS) taken from the offered lot material for the purpose of acceptance of that lot of material. 1) Dimension of all type of Lugs as per IS 8309:1993.

Initiator	<i>Suryakanta Mohanty</i>	HOD (Engineering)	<i>Sanku P.D.</i>
-----------	---------------------------	-------------------	-------------------

TPNODL TP NORTHERN ODISHA DISTRIBUTION LIMITED <small>(A Tata Power and Odisha Government Joint Venture)</small>	TP NORTHERN ODISHA DISTRIBUTION LIMITED		
	TECHNICAL SPECIFICATIONS		
Doc. Title	SPECIFICATION FOR LT DEAD END CLAMP		
Doc. No	ENG-LV-006	Eff. Date: 08-11-2021	
Rev No.	00	Page 7 of 12	
Prepared by: Engineering Department	Reviewed by:	Approved by:	Issued by:

		2) Electrical Conductivity test. 3) Surface Finish. 4) Flattening Test.
7.3	ACCEPTANCE TEST	1) Dimension of all type of Lugs as per IS 8309:1993. 2) Surface Finish.
8.0	TYPE TEST CERTIFICATE	The Bidder shall furnish the type test certificates of files for the tests as mentioned above as per the corresponding standards. All the tests shall be conducted at CPRI or NABL accredited Lab as per the relevant standards. Type tests should have been conducted in certified Test laboratories during the period not exceeding 5 years from the date of opening the bid. In the event of any discrepancy in the test reports, i.e. any test report not acceptable, same shall be carried out without any cost implication to TPNODL
9.0	PRE-DESPATCH INSPECTION	9.1- Material shall be subjected to Visual inspection. 9.2- Unit shall be subject to inspection by a duly authorized representative of the TPNODL. Inspection may be made at any stage of manufacture at the option of the purchaser and the unit if found unsatisfactory as to workmanship or material, the same is liable to rejection. Bidder shall grant free access to the places of manufacture to TPNODL's representatives at all times when the work is in progress. Inspection by the TPNODL or its authorized representatives shall not relieve the supplier of his obligation of furnishing equipment in accordance with the specifications. Material shall be dispatched after specific MDCC (Material Dispatch Clearance Certificate) is issued by TPNODL. Following documents shall be sent along with material: a) Test reports b) MDCC issued by TPNODL c) Invoice in duplicate d) Packing list e) Drawings & catalogue f) Guarantee / Warrantee card g) Delivery Challan h) Other Documents (as applicable)
10.0	INSPECTION AFTER RECEIPT AT STORE	The material received at TPNODL, Balasore, Odisha store shall be inspected for acceptance and shall be liable for rejection, if found different from the reports of the pre-dispatch inspection.
11.0	GUARANTEE	Bidder shall stand guarantee towards design, materials, workmanship & quality of process/ manufacturing of items under the contract for due and intended performance of the same, as an integrated product delivered under this contract. In the event any defect is found by the Purchaser up to a period of 12 months from the date of commissioning and 18 months from the date of last supplies made under the contract,

Initiator	<i>Suryakanta Mohanty</i>	HOD (Engineering)	<i>Sanku P.D.</i>
-----------	---------------------------	-------------------	-------------------

TPNODL TP NORTHERN ODISHA DISTRIBUTION LIMITED <small>(A Tata Power and Odisha Government Joint Venture)</small>	TP NORTHERN ODISHA DISTRIBUTION LIMITED		
	TECHNICAL SPECIFICATIONS		
Doc. Title	SPECIFICATION FOR LT DEAD END CLAMP		
Doc. No	ENG-LV-006	Eff. Date: 08-11-2021	
Rev No.	00	Page 8 of 12	
Prepared by: Engineering Department	Reviewed by:	Approved by:	Issued by:

		<p>whichever is later. Bidder shall be liable to undertake to replace/rectify such defects at his own costs. within mutually agreed timeframe, and to the entire satisfaction of the Purchaser, failing which the Purchaser will be at liberty to get it replaced/rectified at Bidder's risks and costs and recover all such expenses plus the Purchaser's own charges (@ 20% of expenses incurred), from the Bidder or from the " Security cum Performance Deposit" as the case may be.</p> <p>Bidder shall further be responsible for 'free replacement' for another period of THREE years from the end of the guarantee period for any 'Latent Defects' if noticed and reported by TPNODL.</p>
12.0	PACKING	Bidder shall ensure that all the Aluminum lugs covered under this specification shall be prepared for rail/road transport in a manner so as to protect the equipment from damage in transit.
13.0	TENDER SAMPLE	Bidders are required to manufacture 2 sample of Lugs as per the Purchaser's specification and submit the sample along with the bid to Contracts for approval.
14.0	QUALITY CONTROL	<p>The bidder shall have a prove track of not less than 5 years in manufacturing and servicing of Aluminum Lugs in Indian market .The bidder shall submit with the offer Quality assurance plan indicating the various stages of inspection, the tests and checks which will be carried out on the material of construction, components during manufacture and bought out items and fully assembled component and equipment after finishing. As part of the plan, a schedule for stage and final inspection within the parameters of the delivery schedule shall be furnished. The Purchaser's engineer or its nominated representative shall have free access to the manufacturer's/sub-supplier's works to carry out inspections.</p> <p>14.1 The Bidder shall invariably furnish following information along with his bid, failing which the bid shall be liable for rejection. Information shall be separately given for individual type of equipment offered.</p> <p>a) Statement giving list of important raw materials, names of sub-suppliers for the raw materials, list of standards according to which the raw materials are tested. List of tests normally carried out on raw materials in the presence of Bidder's representative, copies of test certificates.</p> <p>b) Information and copies of test certificates as in (a) above in respect of bought out accessories.</p> <p>c) List of manufacturing facilities available.</p> <p>d) Level of automation achieved and list of areas where manual processing exists.</p> <p>e) List of areas in manufacturing process, where stage inspections are normally carried out for quality control and details of such tests and inspection.</p>

Initiator	<i>Suryakanta Mohanty</i>	HOD (Engineering)	<i>Sanku P.D.</i>
-----------	---------------------------	-------------------	-------------------

TPNODL TP NORTHERN ODISHA DISTRIBUTION LIMITED <small>(A Tata Power and Odisha Government Joint Venture)</small>	TP NORTHERN ODISHA DISTRIBUTION LIMITED		
	TECHNICAL SPECIFICATIONS		
Doc. Title	SPECIFICATION FOR LT DEAD END CLAMP		
Doc. No	ENG-LV-006	Eff. Date: 08-11-2021	
Rev No.	00	Page 9 of 12	
Prepared by: Engineering Department	Reviewed by:	Approved by:	Issued by:

		<p>f) List of testing equipment available with the bidder for final testing of equipment along with valid calibration reports shall be furnished with the bid. Manufacturer shall possess 0.1 class instruments for measurement of losses.</p> <p>g) Quality Assurance Plan (QAP) withholds points for purchaser's inspection.</p> <p>14.2 The successful Bidder shall within 30 days of placement of order, submit following information to the purchaser.</p> <p>a) List of raw materials as well as bought out accessories and the names of sub-Suppliers selected from those furnished along with offer.</p> <p>b) Type test certificates of the raw materials and bought out accessories.</p> <p>14.3 The successful Bidder shall submit the routine test certificates of bought out accessories and central excise passes for raw material at the time of routine testing.</p>
15.0	MINIMUM TESTING FACILITIES	Bidder shall have adequate in house testing facilities for carrying out all routine /acceptance tests and pre-dispatch inspection as per relevant International / Indian standards.
16.0	MANUFACTURING ACTIVITIES	The successful bidder will have to submit the bar chart for various manufacturing activities clearly elaborating each stage, with quantity. This bar chart should be in line with the Quality assurance plan submitted with the offer. This bar chart will have to be submitted within 15 days from the release of the order.
17.0	SPARES, ACCESSORIES AND TOOLS	N.A.
18.0	DRAWINGS AND DOCUMENTS	<p>Following documents shall be prepared based on TPNODL specifications and statutory requirements with complete BOM and shall be submitted with the bid:</p> <p>a) Completely filled in Technical Particulars.</p> <p>b) General description of the equipment and all components including brochures.</p> <p>c) Bill of Material</p> <p>d) Type test Certificates</p> <p>e) Experience List.</p> <p>After the award of the contract, four (4) copies of the drawings, drawn to scale, describing the equipment in detail shall be forwarded for approval and shall subsequently provide four (4) complete sets of final drawings, one of which shall be auto positive suitable for reproduction, before the dispatch of the equipment. Soft copy (Compact Disk CD) of all the drawing, GTP, test certificates shall be submitted after the final approval of the same to the TPNODL.</p> <p>Following Drawings/Documents shall be submitted after the award of the contract:</p>

Initiator	<i>Suryakanta Mohanty</i>	HOD (Engineering)	<i>Sanku P.D.</i>
-----------	---------------------------	-------------------	-------------------

TPNODL TP NORTHERN ODISHA DISTRIBUTION LIMITED <small>(A Tata Power and Odisha Government Joint Venture)</small>	TP NORTHERN ODISHA DISTRIBUTION LIMITED		
	TECHNICAL SPECIFICATIONS		
Doc. Title	SPECIFICATION FOR LT DEAD END CLAMP		
Doc. No	ENG-LV-006	Eff. Date: 08-11-2021	
Rev No.	00	Page 10 of 12	
Prepared by: Engineering Department	Reviewed by:	Approved by:	Issued by:

S. No	Description	For Approval	For Review Information	Final Submission
1	Technical Parameters	√		√
2	Manual/Catalogues/drawings for all components.		√	
3	Technical details and test certificates of the component.		√	√
4	Instructions for use		√	√
5	Transport/shipping dimension drawing		√	√
6	QA & QC Plan	√	√	√
7	Routine, Acceptance and Type test Certificates	√	√	√

All the Documents and Drawings shall be in English Language.

19.0	GUARANTEED TECHNICAL PARTICULARS	S.No	Conductor size	Dimension of Lugs (mm)									
				E	A	C	D	F	B	H	G	L	J
		1	Lugs Al crimping 4 sq.mm XLPE single hole	Bidder has to Submit									
		2	Lugs Al crimping 10 sq.mm XLPE single hole										
		3	Lugs Al crimping 25 sq.mm XLPE single hole										
		4	Lug Al crimping 35 sq.mm for 7/10 SWG Stay wire										
		5	Lugs Al crimping 50 sq.mm XLPE single hole										
		6	Lug Al crimping 70 sq.mm for 7/8 SWG Stay wire										
		7	Lugs Al crimping 95 sq.mm XLPE single hole										
		8	Lugs Al crimping 150 sq.mm XLPE single hole										
		9	Lugs Al crimping 185 sq.mm XLPE single hole										
		10	Lugs Al crimping 1C*300 sq.mm XLPE single hole circular										
		11	Lugs Al crimping 4C*300 sq.mm XLPE single hole sector shaped										
12	Lugs Al crimping 400 sq.mm XLPE single hole												

Initiator	<i>Suryakanta Mohanty</i>	HOD (Engineering)	<i>Sanku P.D.</i>
-----------	---------------------------	-------------------	-------------------

TPNODL TP NORTHERN ODISHA DISTRIBUTION LIMITED <small>(A Tata Power and Odisha Government Joint Venture)</small>	TP NORTHERN ODISHA DISTRIBUTION LIMITED		
	TECHNICAL SPECIFICATIONS		
Doc. Title	SPECIFICATION FOR LT DEAD END CLAMP		
Doc. No	ENG-LV-006	Eff. Date: 08-11-2021	
Rev No.	00	Page 11 of 12	
Prepared by: Engineering Department	Reviewed by:	Approved by:	Issued by:

		13	Lugs Al crimping 630 sq.mm XLPE single hole	
		14	Lugs Al crimping 300 sq.mm XLPE double hole	
		15	Lugs Al crimping 630 sq.mm XLPE double hole	
		16	Surface Finish	
		17	Electrical Conductivity test	
		18	Flattening Test	

20.0	SCHEDULE OF DEVIATIONS	<u>(TO BE ENCLOSED WITH THE BID)</u>						
		<p>All deviations from this specification shall be set out by the Bidders, clause by Clause in this schedule. Unless specifically mentioned in this Schedule, the tender shall be deemed to confirm the purchaser's specifications:</p> <table border="1" style="width: 100%; border-collapse: collapse;"> <thead> <tr> <th style="width: 10%;">S.No.</th> <th style="width: 20%;">Clause No.</th> <th style="width: 70%;">Details of deviation with justifications</th> </tr> </thead> <tbody> <tr> <td style="height: 200px;"></td> <td></td> <td></td> </tr> </tbody> </table> <p>We confirm that there are no deviations apart from those detailed above.</p> <p>Seal of the Company:</p> <div style="text-align: right; margin-top: 20px;"> <p>Signature</p> <p>Designation</p> </div>			S.No.	Clause No.	Details of deviation with justifications	
S.No.	Clause No.	Details of deviation with justifications						

Initiator	<i>Suryakanta Mohanty</i>	HOD (Engineering)	<i>Sanku P.D.</i>
-----------	---------------------------	-------------------	-------------------

TPNODL TP NORTHERN ODISHA DISTRIBUTION LIMITED <small>(A Tata Power and Odisha Government Joint Venture)</small>	TP NORTHERN ODISHA DISTRIBUTION LIMITED		
	TECHNICAL SPECIFICATIONS		
Doc. Title	SPECIFICATION FOR LT DEAD END CLAMP		
Doc. No	ENG-LV-006	Eff. Date: 08-11-2021	
Rev No.	00	Page 12 of 12	
Prepared by: Engineering Department	Reviewed by:	Approved by:	Issued by:

Initiator	<i>Suryakanta Mohanty</i>	HOD (Engineering)	<i>Sanku P.D.</i>
-----------	---------------------------	-------------------	-------------------

TPNODL TP NORTHERN ODISHA DISTRIBUTION LIMITED <small>(A Tata Power and Odisha Government Joint Venture)</small>	TP NORTHERN ODISHA DISTRIBUTION LIMITED		
	TECHNICAL SPECIFICATIONS		
Doc. Title	SPECIFICATION FOR ALUMINIUM BINDING WIRE		
Doc. No	ENG-HV-018	Eff. Date: 23-11-2021	
Rev No.	00	Page 1 of 5	
Prepared by: Engineering Department	Reviewed by:	Approved by:	Issued by:

CONTENTS

1. SCOPE
2. APPLICABLE STANDARDS
3. CLIMATIC CONDITIONS OF THE INSTALLATION
4. GENERAL CONSTRUCTIONS
5. GENERAL TECHNICAL REQUIREMENTS
6. MARKING
7. TESTS
8. PRE-DESPATCH INSPECTION
9. INSPECTION AFTER RECEIPT AT STORES
10. GUARANTEE
11. PACKING AND DELIVERY
12. SCHEDULE OF DEVIATIONS

Initiator	<i>Geeyakanta Mohanty</i>	HOD (Engineering)	<i>Sanku P.D.</i>
-----------	---------------------------	-------------------	-------------------

TPNODL TP NORTHERN ODISHA DISTRIBUTION LIMITED <small>(A Tata Power and Odisha Government Joint Venture)</small>	TP NORTHERN ODISHA DISTRIBUTION LIMITED		
	TECHNICAL SPECIFICATIONS		
Doc. Title	SPECIFICATION FOR ALUMINIUM BINDING WIRE		
Doc. No	ENG-HV-018	Eff. Date: 23-11-2021	
Rev No.	00	Page 2 of 5	
Prepared by: Engineering Department	Reviewed by:	Approved by:	Issued by:

1.0 SCOPE

Scope covers manufacture, testing and supply of 3.53 mm dia Aluminium Binding Wire as per IS 398.

2.0 APPLICABLE STANDARDS

The equipment covered by this specification shall unless otherwise stated, be designed, manufactured, and tested in accordance with latest editions of the following standards/IEC and shall conform to the regulations of local statutory authorities.

3.0 CLIMATIC CONDITIONS OF THE INSTALLATION:

The service conditions shall be as follows:

1. Maximum altitude above sea level 1,200m
2. Maximum ambient air temperature 50°C
3. Maximum daily average ambient air temperature 40°C
4. Minimum ambient air temperature 2°C
5. Maximum relative humidity 99.7%
6. Average number of thunderstorm days per annum (isokeraunic level) 70
7. Average number of rainy days per annum 160
8. Average annual rainfall 1800 mm
9. Earthquakes of an intensity in horizontal direction - equivalent to seismic acceleration of 0.3g
10. Earthquakes of an intensity in vertical direction - equivalent to seismic acceleration of 0.15g (g being acceleration due to gravity)
- 11 .Wind velocity: 200 km/hr.

Note: The atmosphere across coastal divisions of TPNODL is very saline, laden with salt, acid and dust suspended during dry months and subjected to fog in cold months. The design of the equipment and accessories shall be suitable to withstand seismic forces corresponding to an acceleration of 0.3g.

4.0 GENERAL CONSTRUCTIONS:

The material comprising the wire shall have the following chemical composition:

Aluminium 99.95% minimum Copper, silicon and iron 0.05% maximum

The surface of the wire shall be smooth and free from all irregularities and imperfections. Its cross sections shall closely approximate that of true circle.

The surface of the finished wires shall be checked to ensure that it is smooth ,free from all irregularities, imperfections and inclusions and that its cross section approximates closely that of true circle.

Initiator	<i>Beejankanta Mohanty</i>	HOD (Engineering)	<i>Sanku P.D.</i>
-----------	----------------------------	-------------------	-------------------

TPNODL TP NORTHERN ODISHA DISTRIBUTION LIMITED <small>(A Tata Power and Odisha Government Joint Venture)</small>		TP NORTHERN ODISHA DISTRIBUTION LIMITED	
		TECHNICAL SPECIFICATIONS	
Doc. Title		SPECIFICATION FOR ALUMINIUM BINDING WIRE	
Doc. No	ENG-HV-018	Eff. Date: 23-11-2021	
Rev No.	00	Page 3 of 5	
Prepared by: Engineering Department	Reviewed by:	Approved by:	Issued by:

The wire shall be checked to ensure that its diameter and weight are within the values given in the table below characteristic of an aluminium binding wire.

When tested on a standard tensile testing machine, the value obtained for the ultimate tensile stress shall not be less than 1.57kN.

5.0 GENERAL TECHNICAL REQUIREMENTS

DIAMETER OF WIRE			CROSS-SECTIONAL AREA OF NOMINAL DIA. WIRES (MM)	WEIGHT OF WIRE KG/KM	BREAKING LOAD (KN)
MINIMUM	NOMINAL	MAXIMUM			
3.15	3.53	3.55	9.787	26.45	1.57

6.0 MARKING:

The unit shall be appropriately marked as "**PROPERTY OF TPNODL, BALASORE**" and with the name of the vendor and year of manufacturing at suitable location.

7.0 TESTS

All routine, acceptance & type tests shall be carried out in accordance with the relevant IS/IEC.

All routine/acceptance tests shall be witnessed by the purchaser/his authorized representative. All components shall also be type tested as per the relevant standards.

Wrapping Test: The wire shall withstand one cycle of a wrapping test as follows:

The wire shall be closely wrapped round a wire of its own diameter form a close helix of eight turns. Six turns shall then be unwrapped and again closely rewrapped in the same direction as the first wrapping. The wire shall not break or crack when subjected to this test.

8.0 PRE DISPATCH INSPECTION

Equipment shall be subjected to inspection by a duly authorized representative of TPNODL. Inspection may be made at any stage of manufacture at the discretion of the purchaser and the equipment, if found unsatisfactory as to workmanship or material, the same is liable to rejection. Bidder shall always grant free access to the places of manufacture to TPNODL's representatives when the work is in progress. Inspection by TPNODL or its authorized representatives shall not relieve the bidder of his obligation of furnishing equipment in accordance with the specifications. Material shall be dispatched after specific MDCC (Material Dispatch Clearance Certificate) is issued by TPNODL.

Following documents shall be sent along with material.

- Test reports
- MDCC issued by TPNODL
- Invoice in duplicate
- Packing list
- Drawings & catalogue
- Guarantee / Warrantee card

Initiator	<i>Beejankanta Mohanty</i>	HOD (Engineering)	<i>Sanku P.D.</i>
-----------	----------------------------	-------------------	-------------------

TPNODL TP NORTHERN ODISHA DISTRIBUTION LIMITED <small>(A Tata Power and Odisha Government Joint Venture)</small>	TP NORTHERN ODISHA DISTRIBUTION LIMITED		
	TECHNICAL SPECIFICATIONS		
Doc. Title	SPECIFICATION FOR ALUMINIUM BINDING WIRE		
Doc. No	ENG-HV-018	Eff. Date: 23-11-2021	
Rev No.	00	Page 4 of 5	
Prepared by: Engineering Department	Reviewed by:	Approved by:	Issued by:

- g) Delivery Challan
h) Other Documents (as applicable)

9.0 INSPECTION AFTER RECEIPT AT STORES

The material received at TPNODL, BALASORE, Odisha store will be inspected for acceptance and shall be liable for rejection, if found different from the reports of the pre-dispatch inspection and one copy of the report shall be sent to Plant Engineering department.

10.0 GUARANTEE

Bidder shall stand guarantee towards design, materials, workmanship & quality of process / manufacturing of items under this contract for due and intended performance of the same, as an integrated product delivered under this contract. In the event any defect is found by the Company up to a period of at least 12 months from the date of commissioning or 24 months from the date of last supplies made under the contract whichever is later. In the event any defect is found by the Company up to a period of 12 months from the date of commissioning or 24 months from the date of last supplies made under the contract, whichever is earlier, supplier shall be liable to undertake to replace/rectify such defects at his own costs.

11.0 PACKING AND DELIVERY

The aluminium binding wire shall be delivered in 30m coils, with a permitted tolerance of +5%. Random or non-standard lengths shall not be permitted.

Each coil shall be adequately guarded against damage due to transportation and handling and shall have an outer layer of tightly wound polythene tape or be contained in a suitable, transparent plastic bag.

The internal diameter of the wound coil shall not be such as to result in a permanent set in the conductor.

The coils shall be contained in non-returnable wooden cases, with a gross weight not in excess of 300 kg. The number of coils contained shall be marked on the outside of each case.

12.0 SCHEDULE OF DEVIATIONS

SCHEDULE OF DEVIATIONS

(TO BE ENCLOSED WITH TECHNICAL BID)

All deviations from this specification shall be set out by the Bidders, clause by Clause in this schedule. Unless specifically mentioned in this Schedule, the tender shall be deemed to confirm the purchaser's specifications:

S.No	Clause No.	Details of deviation with justifications
------	------------	--

Initiator	<i>Beejankanta Mohanty</i>	HOD (Engineering)	<i>Sanku P.D.</i>
-----------	----------------------------	-------------------	-------------------

TPNODL TP NORTHERN ODISHA DISTRIBUTION LIMITED <small>(A Tata Power and Odisha Government Joint Venture)</small>	TP NORTHERN ODISHA DISTRIBUTION LIMITED		
	TECHNICAL SPECIFICATIONS		
Doc. Title	SPECIFICATION FOR ALUMINIUM BINDING WIRE		
Doc. No	ENG-HV-018	Eff. Date: 23-11-2021	
Rev No.	00	Page 5 of 5	
Prepared by: Engineering Department	Reviewed by:	Approved by:	Issued by:

--	--	--

We confirm that there are no deviations apart from those detailed above.

Seal of the Company:

Signature
Designation

Initiator	<i>Beejankanta Mohanty</i>	HOD (Engineering)	<i>Sanku P.</i>
-----------	----------------------------	-------------------	-----------------

 TPNODL <small>TP NORTHERN ODISHA DISTRIBUTION LIMITED</small> <small>(A Tata Power and Odisha Government Joint Venture)</small>	TP NORTHERN ODISHA DISTRIBUTION LIMITED		
	TECHNICAL SPECIFICATIONS		
Doc. Title	SPECIFICATION FOR BACK CLAMP FOR “V” CROSS ARMS USED IN 33 KV LINES		
Doc. No:	ENG-EHV-009	Eff. Date: 23.11.2021	
Rev No:	00	Page 1 of 7	
Prepared by:	Reviewed by:	Approved by:	Issued by:

CONTENTS

1. SCOPE
2. APPLICABLE STANDARDS
3. CLIMATIC CONDITIONS OF THE INSTALLATION
4. GENERAL TECHNICAL REQUIREMENTS
5. MARKING
6. TESTS
7. TYPE TEST CERTIFICATES
8. PRE-DESPATCH INSPECTION
9. INSPECTION AFTER RECEIPT AT STORES
10. GUARANTEE
11. PACKING
12. TENDER SAMPLE
13. QUALITY CONTROL
14. MINIMUM TESTING FACILITIES
15. MANUFACTURING ACTIVITIES
16. DRAWINGS
17. SCHEDULE OF DEVIATIONS

 TP NORTHERN ODISHA DISTRIBUTION LIMITED		TECHNICAL SPECIFICATIONS	
Doc. Title		SPECIFICATION FOR BACK CLAMP FOR "V" CROSS ARMS USED IN 33 KV LINES	
Doc. No:	ENG-EHV-009	Eff. Date: 23.11.2021	
Rev No:	00	Page 2 of 7	
Prepared by:	Reviewed by:	Approved by:	Issued by:

1.0 SCOPE

The scope of this document is to give design & constructional features, inspection, supply, and transportation guidelines for back clamp for V Cross arm used in 33 KV lines.

2.0 APPLICABLE STANDARDS

The equipment covered by this specification shall unless otherwise stated, be designed, manufactured, and tested in accordance with latest editions of the following standards/IEC and shall confirm to the regulations of local statutory authorities.

- a) IS 2062:2011 - For Hot rolled medium and high tensile structural steel- specification
- b) IS 1852-1985 - For Rolling and cutting tolerances for hot rolled steel products
- c) IS 2629-1985 - For Recommended practice for hot dip galvanized of iron and steel
- d) IS 4759-1996 - For Hot dip zinc coatings on structural steel and other allied products- specification
- e) IS 808-1989 - Dimensions for Hot Rolled Steel Beam, Column, Channel and Angle Sections

3.0 CLIMATIC CONDITIONS OF THE INSTALLATION:



The service conditions shall be as follows:

1. Maximum Ambient Temperature	50°c
2. Maximum daily average ambient temperature	40°c
3. Minimum Ambient Temperature	2°c
4. Maximum humidity	99.7%
5. Minimum humidity	15%
6. Average Annual Rainfall	1800mm
7. Average wind speed prevailing in the area	200kmph
8. Average Thunderstorms prevailing in the area	70 days per annum
9. Average Dust storms prevailing in the area	20 days per annum
10. Average number of rainy days per annum	160
11. Maximum Altitude above sea level	1200m
12. Rainy months	June to October

Where the work will take place includes coastal areas, subject to high relative humidity, which can give rise to condensation. Onshore winds will frequently be salt laden. On occasions, the combination of salt and condensation may create pollution conditions for outdoor insulators. Some places are in heavily industrial polluted areas. Therefore, Outdoor material and equipment shall be designed and protected for use in exposed, heavily polluted, salty, corrosive and humid coastal atmosphere. The design of the equipment and accessories shall be suitable to withstand seismic forces corresponding to an acceleration of 0.3g.

4.0 GENERAL TECHNICAL REQUIREMENTS

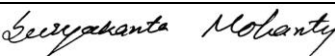
SL. NO.	DESCRIPTION	UNIT	REQUIREMENT
1.	Type of Clamp		Back Clamp for 33 KV 'V' CROSS ARM

Initiator		HOD (Engineering)	
-----------	---	-------------------	---

TPNODL <small>TP NORTHERN ODISHA DISTRIBUTION LIMITED (A Tata Power and Odisha Government Joint Venture)</small>		TP NORTHERN ODISHA DISTRIBUTION LIMITED TECHNICAL SPECIFICATIONS	
Doc. Title		SPECIFICATION FOR BACK CLAMP FOR "V" CROSS ARMS USED IN 33 KV LINES	
Doc. No:	ENG-EHV-009	Eff. Date: 23.11.2021	
Rev No:	00	Page 3 of 7	
Prepared by:	Reviewed by:	Approved by:	Issued by:

2.	Grade of Steel		FY-250
3	Steel Standards		IS: 2062/1992
4	Fabrication Standards		IS: 8029 (Part-2):1978
5	Dimension	mm	50x8 mm MS Flat
6	Steel Sections Utilized		50x8 mm MS Flat
7	Steel Tensile Strength	N/cm ²	1500 Kg. f/cm ²
8	Working Load	Kg.	200/300 Kg
9	Details of Construction Standard		
10	Details of Galvanizing Method Utilized and Standard/ Specification Conforming to?		NA
11	Weight of Back Clamp for 33 KV V Cross Arm (min.)	Kg.	2.4
12	Whether Drawing has been Submitted with the Bid		Yes/No

5.0 MARKING:

The unit shall be appropriately marked as "**PROPERTY OF TPNODL**" and with the name of the vendor and year of manufacturing at suitable location.

6.0 TESTS

All routine, acceptance & type tests shall be carried out in accordance with the relevant IS/IEC.

All routine/acceptance tests shall be witnessed by the purchaser/his authorized representative. All components shall also be type tested as per the relevant standards.

Tests	IS to be referred
Visual test	As a routine test
Dimensional tests	As per the drawing
Tensile strength	IS 2062
Bend test	IS 2062
Impact test	IS 2062
Hot dip galvanizing	IS 4759 : 1996

7.0 TYPE TEST CERTIFICATE

The bidder shall furnish the type test certificates of the back clamp for V cross Arm for the tests as mentioned above as per the corresponding standards. All the tests shall be conducted at NABL accredited labs as per the relevant standards. Type tests should have been conducted during the period not exceeding 5 years from the date of opening the bid. In the event of any discrepancy in the test reports i.e. any test report not acceptable or any/all type tests (including additional type tests, if any) not carried out, same shall be carried out without any cost implication to TPNODL.

Initiator	<i>Sreyasanta Mohanty</i>	HOD (Engineering)	<i>Sanku P.D.</i>
-----------	---------------------------	-------------------	-------------------

TPNODL TP NORTHERN ODISHA DISTRIBUTION LIMITED <small>(A Tata Power and Odisha Government Joint Venture)</small>	TP NORTHERN ODISHA DISTRIBUTION LIMITED		
	TECHNICAL SPECIFICATIONS		
Doc. Title	SPECIFICATION FOR BACK CLAMP FOR "V" CROSS ARMS USED IN 33 KV LINES		
Doc. No:	ENG-EHV-009	Eff. Date: 23.11.2021	
Rev No:	00	Page 4 of 7	
Prepared by:	Reviewed by:	Approved by:	Issued by:

8.0 PRE DISPATCH INSPECTION

Equipment shall be subjected to inspection by a duly authorized representative of TPNODL. Inspection may be made at any stage of manufacture at the discretion of the purchaser and the equipment, if found unsatisfactory as to workmanship or material, the same is liable to rejection. Bidder shall always grant free access to the places of manufacture to TPNODL's representatives when the work is in progress. Inspection by TPNODL or its authorized representatives shall not relieve the bidder of his obligation of furnishing equipment in accordance with the specifications. Material shall be dispatched after specific MDCC (Material Dispatch Clearance Certificate) is issued by TPNODL.

Following documents shall be sent along with material.

- a) Test reports
- b) MDCC issued by TPNODL.
- c) Invoice in duplicate
- d) Packing list
- e) Drawings & catalogue
- f) Guarantee / Warrantee card
- g) Delivery Challan
- h) Other Documents (as applicable)

9.0 INSPECTION AFTER RECEIPT AT STORES

The material received at TPNODL, Balasore, Odisha store will be inspected for acceptance and shall be liable for rejection, if found different from the reports of the pre-dispatch inspection and one copy of the report shall be sent to Engineering and contracts department.

10.0 GUARANTEE

Bidder shall stand guarantee towards design, materials, workmanship & quality of process / manufacturing of items under this contract for due and intended performance of the same, as an integrated product delivered under this contract. In the event any defect is found by the Company up to a period of at least 48 months from the date of commissioning or 60 months from the date of last supplies made under the contract whichever is later. In the event any defect is found by the Company up to a period of 48 months from the date of commissioning or 60 months from the date of last supplies made under the contract, whichever is earlier, supplier shall be liable to undertake to replace/rectify such defects at his own costs.

11.0 PACKING

Bidder shall ensure that all the equipment covered under this specification shall be prepared for rail/road transport in a manner to protect the equipment from damage in transit.

12.0 TENDER SAMPLE

Not required.

13.0 QUALITY CONTROL

The bidder shall submit with the offer Quality assurance plan indicating the various stages of inspection, the tests and checks which will be carried out on the material of construction, components during manufacture and bought out items and fully assembled component and equipment after finishing. As part of the plan, a schedule for stage and final inspection within the parameters of the delivery schedule shall be furnished.

Initiator	<i>Suryakanta Mohanty</i>	HOD (Engineering)	<i>Sanku P.D.</i>
-----------	---------------------------	-------------------	-------------------

 TP NORTHERN ODISHA DISTRIBUTION LIMITED TECHNICAL SPECIFICATIONS	
Doc. Title	SPECIFICATION FOR BACK CLAMP FOR "V" CROSS ARMS USED IN 33 KV LINES
Doc. No:	ENG-EHV-009 Eff. Date: 23.11.2021
Rev No:	00 Page 5 of 7
Prepared by:	Reviewed by: Approved by: Issued by:

TPNODL's engineer or its nominated representative shall have free access to the manufacturer's/sub-supplier's works to carry out inspections.

14.0 MINIMUM TESTING FACILITIES

Bidder shall have adequate in-house testing facilities for carrying out all routine tests & acceptance tests as per relevant International / Indian standards

15.0 MANUFACTURING ACTIVITIES

The successful bidder will have to submit the bar chart for various manufacturing activities clearly elaborating each stage, with quantity. This bar chart should be in line with the Quality assurance plan submitted with the offer. This bar chart will have to be submitted within 15 days from the release of the order.

16.0 DRAWINGS

Following drawings & documents shall be prepared based on Purchaser's specifications and statutory requirements with complete BOM and shall be submitted with the bid:



- a) General description of the equipment and all components including brochures
- b) General arrangement drawings
- c) Type Test Certificates.
- d) Experience List
- e) Manufacturing schedule and test schedule.

After the contract, four (4) copies of the drawings, drawn to scale, describing the equipment in detail shall be forwarded for approval and shall subsequently provide four (4) complete sets of final drawings, one of which shall be auto positive suitable for reproduction, before the dispatch of the equipment. Soft copy (Compact Disk CD) of all the drawing, test certificates shall be submitted after the final approval of the same to the purchaser.

Following Drawings/Documents shall be submitted after the award of the contract:
 Drawings/documents to be submitted after the award of the contract:

S.No	Description	For Approval	For Review Information	Final Submission
1	Technical Parameters	√		√
2	General Arrangement drawings	√		√
3	Manual/Catalogues/drawings		√	
4	Installation Instructions (if any)		√	√
5	QA & QC Plan	√	√	√
6	Routine, Acceptance & Type Test Certificates	√	√	√

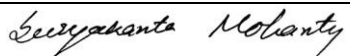
All the documents & drawings shall be in English language.

Initiator		HOD (Engineering)	
-----------	---	-------------------	---

TPNODL <small>TP NORTHERN ODISHA DISTRIBUTION LIMITED</small> <small>(A Tata Power and Odisha Government Joint Venture)</small>	TP NORTHERN ODISHA DISTRIBUTION LIMITED		
	TECHNICAL SPECIFICATIONS		
Doc. Title	SPECIFICATION FOR BACK CLAMP FOR "V" CROSS ARMS USED IN 33 KV LINES		
Doc. No:	ENG-EHV-009	Eff. Date: 23.11.2021	
Rev No:	00	Page 6 of 7	
Prepared by:	Reviewed by:	Approved by:	Issued by:

17.0 SCHEDULE OF DEVIATIONS

SCHEDULE OF DEVIATIONS

(TO BE ENCLOSED WITH TECHNICAL BID)

All deviations from this specification shall be set out by the Bidders, clause by Clause in this schedule. Unless specifically mentioned in this Schedule, the tender shall be deemed to confirm the purchaser's specifications:

S.No	Clause No.	Details of deviation with justifications

We confirm that there are no deviations apart from those detailed above.

Seal of the Company:

Signature
Designation

Initiator	<i>Suryakanta Mohanty</i>	HOD (Engineering)	<i>Sanku P.D.</i>
-----------	---------------------------	-------------------	-------------------

TPNODL <small>TP NORTHERN ODISHA DISTRIBUTION LIMITED (A Tata Power and Odisha Government Joint Venture)</small>	TP NORTHERN ODISHA DISTRIBUTION LIMITED		
	TECHNICAL SPECIFICATIONS		
Doc. Title	SPECIFICATION FOR BACK CLAMP FOR "V" CROSS ARMS USED IN 33 KV LINES		
Doc. No:	ENG-EHV-009	Eff. Date: 23.11.2021	
Rev No:	00	Page 7 of 7	
Prepared by:	Reviewed by:	Approved by:	Issued by:

GUARANTEED TECHNICAL PARTICULAR (BACK CLAMP FOR "V" CROSS ARMS USED IN 33 KV LINES)
(To be furnished by bidder)

SL. NO.	DESCRIPTION	UNIT	REQUIREMENT	TO BE FURNISHED BY THE BIDDER
1.	Type of Clamp		Back Clamp for 33 KV 'V' CROSS ARM	
2.	Grade of Steel		FY-250	
3	Steel Standards		IS: 2062/1992	
4	Fabrication Standards		IS: 8029 (Part-2):1978	
5	Dimension	mm	50x8 mm MS Flat	
6	Steel Sections Utilized		50x8 mm MS Flat	
7	Steel Tensile Strength	N/cm ²	1500 Kg. f/cm ²	
8	Working Load	Kg.	200/300 Kg	
9	Details of Construction Standard			
10	Details of Galvanizing Method Utilized and Standard/ Specification Conforming to?		NA	
11	Weight of Back Clamp for 33 KV V Cross Arm (min.)	Kg.	2.4	
12	Whether Drawing has been Submitted with the Bid		Yes/No	

Initiator	<i>Suryakanta Mohanty</i>	HOD (Engineering)	<i>Sanku P.D.</i>
-----------	---------------------------	-------------------	-------------------

Doc. Title

GENERAL CONDITIONS OF CONTRACT –SUPPLY ORDERS

Rev. No

01 (01.12.2021)

Page 1 of 47

Prepared By

Imran Ahmad/ Swetaraj Parida

Reviewed By

Vipin Chauhan

VIPIN CHAUHAN

Digitally signed by VIPIN CHAUHAN
Date: 2021.12.04 15:13:25 +05'30'

Approved By

Sunil Bhattar

SUNIL

BHATTAR

Digitally signed by SUNIL BHATTAR
DN: cn=, o=Personal, postalCode=122018,
st=Haryana,
serialNumber=F53CC668A7C5989A74C119
99ACB3A85E57C01F8A37FE5E1358B38
297F0F38, cn=SUNIL BHATTAR
Date: 2021.12.04 15:23:36 +05'30'

CONTENTS

CLAUSE NO.	DESCRIPTION
1.0	ORGANIZATIONAL VALUES
2.0	ETHICS
2.1	Tata Code of Conduct
3.0	CONTRACT PARAMETERS
3.1	Issue/Award of Contract
3.2	Contract Commencement Date
3.3	Contract Completion Date
3.4	Contract Period/ Time
3.5	Contract Execution Completion Date
3.6	Contract Price /Value
3.7	Contract Document
3.8	Contract Language
3.9	Reverse Auction
4.0	SCOPE OF WORK
4.1	Bid Evaluation- Commercial & Technical
5.0	PRICES/RATES/TAXES
5.1	Changes in statutory Tax Structure
6.0	TERMS OF PAYMENT
6.1	Quantity Variation
6.2	Full and Final Payment
7.0	MODE OF PAYMENT
8.0	SECURITY CUM PERFORMANCE DEPOSIT
9.0	STATUTORY COMPLIANCE
9.1	Compliance to Various Acts
9.2	SA 8000
9.3	Affirmative Action
9.4	MSME Development Act 2006
9.5	ISO 14001
10.0	QUALITY
10.1	Knowledge of Requirements
10.2	Material/Equipment/Works Quality
10.3	Adherence to Rules & Regulations
10.4	Specifications and Standards
11.0	INSPECTION/PARTICIPATION

Doc. Title	GENERAL CONDITIONS OF CONTRACT FOR SUPPLY ORDERS	
Rev. No	01 dtd 01.12.2021	Page 2 of 47

CONTENTS	
CLAUSE NO.	DESCRIPTION
11.1	Right to Carry Out Inspection
11.2	Facilitating Inspection
11.3	Third Party Nomination
11.4	Waiver of Inspections
11.5	Incorrect Inspection Call
12.0	MDCC & DELIVERY OF MATERIALS
12.1	Material Dispatch Clearance Certificate
12.2	Right to Rejection on Receipt
12.3	Consignee
12.4	Submission of Mandatory Documents on Delivery
12.5	Dispatch and Delivery Instructions
13.0	GUARANTEE
13.1	Guarantee of Performance
13.2	Guarantee period
13.3	Failure in Guarantee period (GP)
13.4	Cost of repairs on failure in GP
13.5	Guarantee Period for Goods Outsourced
13.6	Latent Defect
13.7	Support beyond the Guarantee Period
14.0	LIQUIDATED DAMAGES
14.1	LD Waiver Request
15.0	UNLAWFUL ACTIVITIES
16.0	CONFIDENTIALITY
16.1	Documents
16.2	Geographical Data
16.3	Associate's Processes
16.4	Exclusions
16.5	Violation
17.0	INTELLECTUAL PROPERTY RIGHTS
18.0	INDEMNITY
19.0	LIABILITY & LIMITATIONS
19.1	Liability
19.2	Limitation of Liability
20.0	FORCE MAJEURE
21.0	SUSPENSION OF CONTRACT
21.1	Suspension for Convenience

Doc. Title	GENERAL CONDITIONS OF CONTRACT FOR SUPPLY ORDERS	
Rev. No	01 dtd 01.12.2021	Page 3 of 47

CONTENTS	
CLAUSE NO.	DESCRIPTION
21.2	Suspension for Breach of Contract Conditions
21.3	Compensation in lieu of Suspension
22.0	TERMINATION OF CONTRACT
22.1	Termination for Default/Breach of Contract
22.2	Termination for Convenience of Associate
22.3	Termination for Convenience of TPNODL
23.0	DISPUTE RESOLUTION AND ARBITRATION
23.1	Governing Laws and jurisdiction
24.0	ATTRIBUTES OF GCC
24.1	Cancellation
24.2	Severability
24.3	Order of Priority
25.0	ERRORS AND OMISSIONS
26.0	TRANSFER OF TITLES
27.0	INSURANCE
28.0	SUGGESTIONS & FEEDBACK
29.0	CONTACT POINTS
30.0	LIST OF ANNEXURES

Doc. Title	GENERAL CONDITIONS OF CONTRACT FOR SUPPLY ORDERS	
Rev. No	01 dtd 01.12.2021	Page 4 of 47

1.0 ORGANIZATIONAL VALUES

The Tata Group has always been a value driven organization. These values continue to direct the Group's growth and businesses. The six core Tata Values underpinning the way we do business are:

Integrity - We must conduct our business fairly, with honesty and transparency. Everything we do must stand the test of public scrutiny.

Understanding - We must be caring, respectful, compassionate and humanitarian towards our colleagues and customers around the world and always work for the benefit of India.

Excellence - We must constantly strive to achieve the highest possible standards in our day to day work and in the quality of goods and services we provide.

Unity - We must work cohesively with our colleagues across the group and with our customers and partners around the world to build strong relationships based on tolerance, understanding and mutual co-operation.

Responsibility - We must continue to be responsible and sensitive to the countries, communities and environments in which we work, always ensuring that what comes from the people goes back to the people many times over.

Agility - We must work in a speedy and responsive manner and be proactive and innovative in our approach.

2.0 Tata Code of Conduct

The Business Associate and TPNODL shall be bound by the provisions/ clauses mentioned in Tata Code of Conduct (TCoC) in all their dealings with stakeholders. The Associate is advised to go through the TCoC document available as Annexure-J.

3.0 CONTRACT PARAMETERS

3.1 Issue/Award of Contract

TPNODL awards the contract to the Associate in writing in the form of Purchase Order (PO) or Rate Contract (RC), hereafter referred as Contract, through in any or all of following modes physical handover / post / e-mail / web document / fax with all the attachments/enclosures which shall be part of the contract document.

On receipt of the contract, the associate shall return to TPNODL copy of the contract document duly signed by legally authorized representative of associate, within two days of Effective Date of Contract for contracts having contract execution time less than 30 days and within five days for all other contracts.

Note- In case of RC though, further Release Orders (RO) shall be issued by TPNODL on RC rates and terms & Conditions as per the requirement of TPNODL.

Doc. Title	GENERAL CONDITIONS OF CONTRACT FOR SUPPLY ORDERS	
Rev. No	01 dtd 01.12.2021	Page 5 of 47

3.2 Contract Commencement Date

The date of issue/award of contract shall be the Effective Date of Contract or Contract Commencement date.

3.3 Contract Completion Date

The date of expiry of Guarantee Period shall be deemed as the Contract Completion Date.

3.4 Contract Period/Time

The period from Contract Commencement Date to Contract Completion Date shall be deemed as the Contract Period/Time.

3.5 Contract Execution Completion Date

The stipulated date for completing the supply as per schedule of quantities shall be deemed as the Contract Execution Completion Date.

3.6 Contract Price /Value

The total all-inclusive price/value mentioned in the PO/RC is the Contract Price/Value and is based on the quantity, unit rates and prices quoted and awarded and shall be subject to adjustment based on actual quantities supplied and accepted and certified by the authorized representative of the company unless otherwise specified in schedule of quantities or in contract documents.

3.7 Contract Document

The Contract Document shall mean and include but not limited to the following:

- NIT/Tender Enquiry, QR, Instruction to Bidders, Special Condition of Contract (SCC) of tender, GCC, Technical & Commercial Specifications including relevant annexure and attachments).
- Bids & Proposals Received from Associate including relevant annexure/attachments.
- RC/PO with agreed deviations from the tender/bid documents.
- All the Inspection and Test reports, Detailed Engineering Drawings.
- Material Dispatch Clearance Certificate (MDCC).
- Minutes of Meeting (MoM)

3.8 Contract Language

All documents, instructions, catalogues, brochures, pamphlets, design data, norms and calculations, drawings, operation, maintenance and safety manuals, reports, labels, on deliveries and any other data shall be in English Language.

The Contract documents and all correspondence between the TPNODL, Third Parties associated with the contract, and the Associate shall be in English language.

However, all signboards required indicating "Danger" and/or security at site and otherwise statutory required shall be in English, Hindi, and local languages.

3.9 Reverse Auction

TPNODL reserves the right to conduct the reverse auction (instead of public opening of price bids) for the products / services being asked for in the tender. The terms and conditions for such reverse auction events shall be as per the Acceptance Form attached in Annexure F. The

Doc. Title	GENERAL CONDITIONS OF CONTRACT FOR SUPPLY ORDERS	
Rev. No	01 dtd 01.12.2021	Page 6 of 47

bidders along with the tender document shall mandatorily submit a duly signed copy of the Acceptance Form as mentioned in the Annexure J as a token of acceptance for the same.

4.0 SCOPE OF WORK

All the activities that are to be undertaken by the Associate to realize the contractual deliverables in completeness form Scope of Work. Following clauses list, but not limited to, major requirements of the scope of work.

The associate shall satisfy himself and undertake fully the technical/commercial requirements of items to be supplied as listed in the Schedule of Quantities together with the tests to be performed /test reports to be furnished before dispatch, arrangement of stage and final inspections during manufacturing as per terms and conditions of contract, technical parameters & delivery terms and conditions including transit insurance to be met in order to fully meet TPNODL's requirements.

Completeness: Any supplies and services which might have not been specifically mentioned in the Contract but are necessary for the scope mentioned in Special Terms & Conditions and/or completeness of the works at the highest possible level, including any royalties, license fees & compensation to be paid, whether incurred by the associates or by a third party for the work covered in the scope, regardless of when incurred, shall be supplied/provided by the associate without any extra cost and within the time schedule for efficient, smooth and satisfactory operation and maintenance of the works at the highest possible level under Indian conditions (but according to international standards for facility of this type), unless expressly excluded from the scope of supplies and services in this Contract.

TPNODL have the right, during the performance of the Contract, to change the scope and/or technical character of the Project and/or of the supplies and services stipulated in the Contract by submitting a request in writing to the Associate. The Associate shall, within fifteen days of receipt of such request from the TPNODL, provide Purchaser with a reasonably detailed estimate of the cost of the change outlined in the request.

In the event, TPNODL requests a change, the Contract price and time shall be adjusted upwards or downwards, as the case may be and shall be mutually agreed to. The associate shall not be entitled to any extension of time unless such changes adversely affect the time schedule.

The Associate shall not proceed with the changes as requested till adjustment of contract price and time schedule where so applicable in terms of or otherwise directed by the TPNODL.

4.1 Bid Evaluation- Commercial & Technical

TPNODL reserves the right to evaluate the bid on below parameters as per the requirement:

Commercial Evaluation: The bid shall be evaluated on the basis of Qualifying Requirement parameters and other commercial parameters as mentioned in tender.

Technical Evaluation: The bid shall be evaluated on the parameters and not limited to Bidder Experience, Bidder Performance with other utility/company, internal performance feedback, Technical Specification, General Technical Parameters (GTP), Layout, Drawings etc.

TPNODL reserves the right to carry out Factory Evaluation of Manufacturer along with the Visit to executed Sites for further evaluation to ascertain bidder's manufacturing capability, quality procedures & Performance of executed works.

Doc. Title	GENERAL CONDITIONS OF CONTRACT FOR SUPPLY ORDERS	
Rev. No	01 dtd 01.12.2021	Page 7 of 47

5.0 PRICES/RATES/TAXES

Unless specified elsewhere in the contract document, the prices/rates are inclusive of cost of finished product for which MDCC will be issued by TPNODL, packaging and forwarding charges, freight and transit insurance charges covering loading at Associate's works, transportation to TPNODL store/site & unloading & delivery at TPNODL stores/TPNODL site, cost of documentation including all the relevant test certificates and other supportive documents to be furnished.

The Prices/Rates are inclusive of all taxes, levies, cess and duties, particularly Goods and Services Tax as applicable. All government levy / taxes shall be paid only when the invoice is submitted according to the relevant act.

The prices/rates shall remain firm till actual completion of entire supply of goods/material/equipment as per contract is achieved and shall remain valid till the completion of the contract.

The prices shall remain unchanged irrespective of TPNODL making changes in quantum in all or any of the schedules of items of contract.

5.1 Changes in Statutory Tax Structure

If rate of any or all of the statutory taxes and duties applicable to the contract changes, such changes shall be incorporated by default if the changes occur within the contract execution time and shall be applicable if the contract is executed by the Associate within the Contract Execution Time.

For execution of contracts beyond contract execution time, where the delay is not attributable to TPNODL no upward revision in tax /duties shall be considered irrespective of changes in the statutory tax structure either within the contract execution time or beyond. However, in such cases, benefits due to any downward revisions in statutory tax rates shall be passed on to TPNODL.

6.0 TERMS OF PAYMENT

On delivery of the materials in good condition and certification of acceptance by TPNODL official, Associate shall submit the Bills/Invoices in original in the name of "TPNODL" to invoice desk, complete with all required documents as under:

- Test Reports (4 sets).
- MDCC issued by TPNODL.
- Packing List.
- Drawing and Catalogue.
- Guarantee/Warranty Card.
- Delivery Challan.
- O&M Manual.
- Copy of Order.
- Minutes of Meeting.

Doc. Title	GENERAL CONDITIONS OF CONTRACT FOR SUPPLY ORDERS	
Rev. No	01 dtd 01.12.2021	Page 8 of 47

- E-Way challan (if applicable)

Bills/ invoices shall mention Supplier's GST Number. TPNODL will make 100% payment within 45 days of submission of the Bill/Invoice complete in all respects and along with all the requisite documents mentioned above, subject to condition that Associate has furnished the requisite Security-cum-Performance Guarantee as stipulated in the contract.

6.1 Quantity Variation

Payment will be made on the basis of actual quantity of supplies/actual measurement of works accepted by TPNODL and not on the basis of contract quantity.

6.2 Full and Final Payment

Full & Final Payment in all contracts shall be made subject to the associate submitting "No Demand Certificate" in the format as per Annexure-C.

7.0 MODE OF PAYMENT

Payment shall be made through crossed RTGS/ NEFT/ Online Net banking mode whichever of the two modes chosen by the Associate, in favour of Associate's Bank Account on TPNODL records, on whose name Contract has been issued. Those Associates opting for the RTGS mode shall submit the details of Bank Account and other details as per annexure G. Further, for any payments made, TPNODL is not responsible for any consequences/disputes Associate have among the owners channel partners, sub-Associates and all such dispute/concerns shall be settled solely by the Associate.

8.0 SECURITY CUM PERFORMANCE DEPOSIT

Associates shall submit within 21 days from the effective date of issue of PO/RC, Security Performance Bank Guarantee (SPBG) in the format as per Annexure B of this document from banks acceptable to TPNODL for:

- (a) 5% of the PO value if purchase order value is more than Rs 5 Crores.
- (b) 10% of the PO value if purchase order value is less than Rs 5 Crores.
- (c) 5% of the RC value in case of Rate Contract. This shall remain valid till the Guarantee period plus one month.

In case, PBG will not submitted by BA within 21 days post awarding the contract, TPNODL will reserve the right to take any appropriate action. However, in case of non-submission of PBG till the date of first bill submission, the amounts towards PBG shall be retained by TPNODL from Bills.

The validity of PBG shall be Guarantee Period of contract, plus one month.

- For PO/RC values less than Rs. 5 lacs, Associate may request for deduction of amount equivalent to SPBG value from their first invoice. Such amount shall be withheld by TPNODL while processing the invoice and shall be released after completion of Guarantee Period plus one month.
- For PO/RC values less than Rs. 3 lacs, the clause (8.0) for Security cum Performance Bank Guarantee (SPBG) shall not be applicable.

Doc. Title	GENERAL CONDITIONS OF CONTRACT FOR SUPPLY ORDERS	
Rev. No	01 dtd 01.12.2021	Page 9 of 47

- In case of RC (Rate Contract) after the expiry of RC validity, Associate shall have to submit SPBG. However, the Associate has the option to re-submit the SPBG as per actual RO (Release Order) value issued against the RC, valid for Guarantee Period plus one month. The Guarantee Period shall be considered as per the last RO issued against the said RC. The original SPBG as submitted against the RC shall be released on submission of the new SPBG to TPNODL. Alternatively, Associate may extend the validity of original SPBG only till the requisite period, i.e. Guarantee Period plus one month.

9.0 STATUTORY COMPLIANCE

9.1 Compliance to Various Acts

Associate should ensure adherence to all applicable laws, rules and regulation applicable under this contract from time to time. In case of violation any risk, costs etc shall be in associates account and keep TDPPL indemnified always till completion of contracts.

9.2 SA 8000

As TPNODL/ Tata Power is SA 8000 compliant, it expects its Associates to follow guidelines of SA 8000:2014 on the following aspects

1. Child Labour
2. Forced or Compulsory Labour
3. Health & Safety
4. Freedom of Association & Right to Collective Bargaining
5. Discrimination
6. Disciplinary Practices
7. Working Hours
8. Remuneration
9. Management System

9.3 Affirmative Action

TPNODL appreciate and welcome the engagement/employment of persons from SC/ST community or any other deprived section of society by their business associates.

Relaxation in Contract Clauses under Affirmative Action for SC/ ST Business Associates**

TPNODL believes that inclusive growth is the key to sustainable development, and to promote the same Policy on Affirmative Action for Scheduled Caste & Scheduled Tribe Communities has been adopted across the company.

Under the same pre-text, and to promote entrepreneurship among SC/ST community TPNODL has taken initiative by proposing relaxations in contract clauses as per below:

S. No	Initiative	for SC/ ST BA's	Guideline Document
1	Tender Fees	100% waiver for SC/ST community	All Open Tenders

Doc. Title	GENERAL CONDITIONS OF CONTRACT FOR SUPPLY ORDERS	
Rev. No	01 dtd 01.12.2021	Page 10 of 47

2	Earnest Money Deposit	50 % relaxation of estimated EMD value	All limited and Open Tenders
3	Performance Bank Guarantee	50% relaxation in PBG for order value above 50 lacs else 25% relaxation	All limited and Open tenders
4	Turnover	25% relaxation in company turnover under qualifying requirement criteria	All Open Tenders

****Classification of BAs under SC/ST shall be governed under following guidelines:**

- Proprietorship/ Single Ownership Firm: Proprietor of the firm should be from SC/ST community. Governing document shall be duly audited balance Sheet for the last FY bearing the name of proprietor.
- Partnership Firm: Only such firms shall qualify which have SC/ST partners holding equal to or more than 50% of the total ownership pattern of the firm. Governing document shall be Partnership Deed and audited balance sheet/ ITR for last FY.
- Private limited company: Only such firms shall qualify which have SC/ST directors holding equal to or more than 50% of the total ownership pattern of the firm. Governing document shall be Memorandum of Understanding (MoU) and/or Article of Association (AoA).

Governing document shall be Memorandum of Understanding (MoU) and/or Article of Association (AoA).

Note: Certification from SC/ST commission shall be required for deciding upon SC/ST status of a person.

9.4 MSME Development ACT 2006

Provisions for Firms falling in The Micro, Small and Medium Enterprise Development Act 2006:-

- Business Associate is requested to inform the TPNODL if they fall under provisions of The Micro, Small and Medium Enterprises Development Act, 2006 legislation, and provide necessary documents to TPNODL. The Associate also needs to mention the relevant details on their invoice/ bill.
- Business Associate shall submit the self-undertaking of registration in MSME category at the time of bidding as well as on an annual basis to TPNODL, enabling them to avail the consequent benefits, failing which TPNODL may take appropriate action against such defaults.
- Business Associates falling in MSME category can avail the following benefits-
 - a. **Tender Fees:** To participate in the tender, MSMEs registered in the State of Odisha shall pay Rs.1,000/- including GST towards cost of tender paper.
 - b. **Earnest Money Deposit (EMD):** EMD shall be exempted for MSME registered in the State of Odisha. However, Bidder shall be barred to participate in the tendering process for a period of 2 years in case it backs out post award of the contract.
 - c. **Qualification Requirement for Open Tenders:** Qualification Requirement of Financial Turnover for MSME registered in the State of Odisha shall be reduced to 20% of the existing criteria. For past experience, instead of relying on the volumes / value of earlier Supplies / Projects, assessment of the Bidder shall be done on the basis of feedback from Customers. Past performance experience at

Approved Copy of GCC (TPNODL)-Rev01

Doc. Title	GENERAL CONDITIONS OF CONTRACT FOR SUPPLY ORDERS	
Rev. No	01 dtd 01.12.2021	Page 11 of 47

Tata Power/ TPNODL and its Group Companies shall supersede feedback from other Customers.

- d. **Reservation for MSME:** TPNODL reserve the rights to procure at least 20% of the total volume of the procurement from MSME registered in the State of Odisha (however, it shall not apply where goods/services are not available with the MSME), subject to matching L1 discovered prices and meeting technical specifications including quality requirements.
- e. **Performance Bank Guarantees:** Performance Bank Guarantee for MSME registered in the State of Odisha shall be 25% of the value normally prescribed.

9.5 ISO 14001

The vendor to confirm whether their organization is ISO 14001 certified. If not, the Vendor must certify that the handling, use and disposal of their product/ by-products conform to practices consistent with sound environment management and local statues. The Vendor shall ensure that all the wastes are disposal in environmental friendly way with strict compliance to applicable laws including adherence to MoEF guidelines with respect to the disposal of batteries, lead waste, copper cables, ash, waste oil, e-waste etc. which shall be disposed through MoEF approved parties only. The vendor shall also dispose off the e-waste generated at the end of the product life cycle at its own costs and risk as per the MoEF guidelines/ Orders

10.0 QUALITY

10.1 Knowledge of Requirements

The Associate shall be deemed to have carefully examined and to have knowledge of the equipment, the general and other conditions, specifications, schedules, drawings, etc. forming part of the Contract and also to have satisfied himself as to the nature and character of the work to be executed and the type of the equipment and duties required including wherever necessary of the site conditions and relevant matters and details. Any information thus procured or otherwise obtained from TPNODL/Consultants shall not in any way relieve the Associate from his responsibility and executing the works in accordance with the terms of contract.

10.2 Material/Equipment/Works Quality

The items / works under the scope of the Associate shall be of the best quality and workmanship according to the latest engineering practice and shall be manufactured from materials of best quality considering strength and durability for their best performance and, in any case, in accordance with the specifications set forth in this Contract. All material shall be new. Substitution of specified material or variation from the process of fabrication/ construction/ manufacture may be permitted but only with the prior written approval of the TPNODL.

10.3 Adherence to Rules & Regulations

The Associate shall procure and/or fabricate/erect all materials and equipment in accordance with all requirements of Central and State enactment, rules and regulations governing such work in India and at site. This shall not be construed as relieving the Associate from complying with any requirement of TPNODL as enumerated in the Contract which may be more rigid than and not contrary to the above mentioned rules, nor providing such construction as may be required by the above mentioned rules and regulations. In case of variance of the Technical

Doc. Title	GENERAL CONDITIONS OF CONTRACT FOR SUPPLY ORDERS	
Rev. No	01 dtd 01.12.2021	Page 12 of 47

Specification from the laws, ordinance, rules and regulations governing the work, the Associate shall immediately notify the same to the TPNODL. It is the sole responsibility of the Associate, however, to determine that such variance exists. Wherever required by rules and regulations, the Associate shall also obtain the statutory authorities' approval for the plant, machinery and equipment to be supplied by the Associate.

10.4 Specifications and Standards

The Associate shall follow all codes and standards referred in the Contract Document. Codes and standards of other may be followed by the Associate with the prior written approval of TPNODL, provided materials, supplies and equipment according to the standard are equal to or better than the corresponding standards specified in the Contract.

Brand names mentioned in the Contract documents are for the purpose of establishing the type and quality of products to be used. The Associate shall not change the brand name and qualities of the bought out items without the prior written approval of the TPNODL. All such products and equipment shall be used or installed in strict accordance with original manufacturer's recommendations, unless otherwise directed by the TPNODL. In any circumstances the codes, specimen and standards prescribed by any government agency should not be violated.

11.0 INSPECTION/PARTICIPATION

11.1 Right to Carry Out Inspection

TPNODL reserves the right to send its representatives for inspection or participation at various stages of contract execution listed below, applicable as per contract construction.

- During basic design and detail engineering of material/ Equipment carried out by Associate /Outsourced Agencies.
- During manufacturing stages of the product at Associate's/Associate's Outsourced Agency's Plant/Facility.
- During Pre-dispatch Inspection and Testing of finished/manufactured product at Associate's/Associate's outsourced Agency's Plant/Facility.
- During Installation & Commissioning Activities/Stages.
- Prior to Clearing of the completed installation for commissioning.
- Any other stage as find appropriate by TPNODL during contract execution time.

All inspections and participations shall be carried out by TPNODL giving written intimation to the Associate or receiving appropriate advance written inspection call from the Associate, unless otherwise specified elsewhere in the contract document.

MDCC request shall be submitted by BA to TPNODL at least 7 days before inspection date.

11.2 Facilitating Inspection

The Associate shall provide all opportunities and information to TPNODL's engineers to get acquainted with the technical know-how and the methods and practices adopted by the Associate in basic and detail engineering. The Associate shall provide documents, drawings, calculations etc. as may be required by TPNODL's Engineers.

The Associate shall provide free of charge office accommodation, office facilities, secretarial services, communication facilities, general and drawing office stationary, etc. as may be

Doc. Title	GENERAL CONDITIONS OF CONTRACT FOR SUPPLY ORDERS	
Rev. No	01 dtd 01.12.2021	Page 13 of 47

reasonably required by the TPNODL's engineers. Similarly, facilities shall also be provided by Associate's outsource agencies/partners/authorized dealers (collectively termed as sub associates) if such basic and detail engineering activities are carried out in the design offices of sub-Associates.

The Associate shall be responsible for the safety of employees of TPNODL/Third Party Agency when they are at the Associate's /Associate's outsource agency's plant or facility for carrying out/witnessing inspection/testing. All statutory safety precautions as applicable shall be followed by the Associate during Inspection Testing. If TPNODL inspectors are not satisfied with the safety arrangements at the plant, TPNODL have the right to call off inspection till such time corrective action is taken by the Associate.

Before raising the call for pre-dispatch final inspection and testing, the Associate shall conduct all the tests—type tests, routine tests etc-as specified in the contract document and submit copies of the test certificates to TPNODL along with the inspection call, for scrutiny of TPNODL.

The Associate and TPNODL shall jointly document all the observations, comments and action points after completion of inspection and it shall be binding on the Associate to provide compliance on all the points requiring compliance and furnish the compliance report to the designated authority of TPNODL for receiving clearance for dispatch of materials

11.3 Third Party Nomination

TPNODL also may nominate a third party for the purpose of carrying out the inspection and such an agency shall be entitled to all the rights and privileges of TPNODL as far as conducting the inspection.

11.4 Waiver of Inspections

TPNODL on its own discretion shall chose to waive off any inspection and ask the Associate to submit all the test reports as applicable as per contract specifications, related to inspection and testing of the goods ordered for scrutiny and clearance for dispatch.

11.5 Incorrect Inspection Call

In case it is observed that the material offered for inspection is not ready at the time of TPNODL inspection visit rendering it as futile, all costs towards such inspection shall be recovered from the BA. Taxes as applicable on such recoveries shall be borne by the BA.

12.0 MDCC & DELIVERY OF MATERIALS

12.1 Material Dispatch Clearance Certificate

Associate shall deliver material/goods/equipment against Supply Contracts or Supply Part of Composite/Service Contracts only after receiving Material Dispatch Clearance Certificate (hereafter termed as MDCC) issued by designated authority of TPNODL. Material delivered at TPNODL stores or at project site without a valid MDCC issued by the designated official of TPNODL shall be rejected. MDCC shall be issued to associate furnishing compliance report on the action points documented during pre-dispatch inspection and testing at Associate's/ Sub Associate's plant/ facility. In case Pre-dispatch inspection is waived at the discretion of TPNODL, then, MDCC shall be issued on receiving all the test reports-routine& type-from the Associate and finding them in order.

The associate shall include and provide for securely protecting and packing the materials so as to avoid loss or damage during handling and transport by air, sea, rail and road or any other means.

Doc. Title	GENERAL CONDITIONS OF CONTRACT FOR SUPPLY ORDERS	
Rev. No	01 dtd 01.12.2021	Page 14 of 47

All such packing shall allow to the extent possible for easy removal and checking at Site. The associate shall take special precautions to prevent rusting of steel and iron parts during transit by sea. Gas seals or other materials shall be utilized by the associate for protection against moisture during transit of all Plant and Equipment.

Each Equipment or parts of Equipment shall be tagged with reference to the assembly drawings and corresponding part numbers. Each bale or package shall contain a packing note quoting specifically the name of the associate, item description, quantity, item / package identification.

All packing cases, containers, packing and other similar materials shall be new and supplied free by the associate and it shall not be required to be returned to the associate.

Notwithstanding anything stated in this clause, the associate shall be entirely responsible for loss, damage or depreciation or deterioration to the materials and supplies due to faulty and/or insecure packing or otherwise during transportation to the Site until otherwise provided herein.

In case of the consignments dispatched by road, the associate shall ensure that it or its subcontractors:

- i) Identify and obtain the correct type of trucks/trailers, keeping in view the nature of consignments to be dispatched.
- ii) Take such actions as may be necessary to avoid all possible chances of damages during transit and to ensure that all packages are firmly secured.

Timelines for inspection and MDCC is as below:

S. No.	Inspection	MDCC issuance time including Inspection time (max.)
1	Outside Odisha	12 days
2	Within Odisha	5 days
3	Waiver*	3 working days

* Associate is expected to raise the inspection call assuming that Inspection shall be carried out by TPNODL. The decision for waiver of inspection shall be on sole discretion of TPNODL.

12.2 Right to Rejection on Receipt

Goods/Material/Equipment delivered in condition physically damaged & incomplete as a product ordered, or not packed and transported as per the terms and conditions of the contract is liable to be rejected. Such item shall be lifted back by Associates within 15 days from receipt of rejection note from TPNODL and have to supply back the material within next 30 days or within the timeframe mutually decided by Associate and TPNODL.

If delivery of the material is beyond the agreed time, Liquidated damage clause, mentioned in this GCC separately shall be applicable; but the period for levy of LD shall be considered as per the original delivery schedule and not from the agreed timelines for material rectification.

12.3 Consignee

Unless otherwise specified in the Contract Document, Materials/Goods/Equipment shall be consigned to "Stores-In-Charge", TPNODL, Balasore/ Jajpur/ others.

Doc. Title	GENERAL CONDITIONS OF CONTRACT FOR SUPPLY ORDERS	
Rev. No	01 dtd 01.12.2021	Page 15 of 47

12.4 Submission of mandatory documents on Delivery

Following documents shall be mandatorily submitted by BA along with supply of material to TPNODL stores/site:

S. No.	Documents	Requisite
1	Invoice copy in original	With all consignments
2	LR copy	Wherever required
3	Packing list	With all consignments
4	MDCC	With all consignments
5	Purchase order / Release order	Signed copy
6	Test certificates	With all consignments
7	Inspection/JVR report	In case pre-dispatch inspection is conducted
8	Device data in CD as per template for metering items	Wherever applicable

12.5 Dispatch and Delivery Instructions

S. No.	Instructions
1	Purchase order/ Release order no. shall be mentioned on invoice and on material
2	TPNODL material code and material description shall be mentioned in invoice and on material.
3	“Property of TPNODL” shall be embossed on material.
4	The material shall be properly sealed and packed in standard packing as per purchase order terms & conditions.
5	The weight and quantity of material shall be mentioned wherever applicable
6	The material supplied shall be co-related with the packing list.
7	The name plate detail on equipment shall include Material code, Material description, specification detail of material [as applicable], Serial No. Year of manufacturing, PO/RO no. and date, “PROPERTY OF TPNODL”, Guarantee period and Associate’s name.
8	In case of manual unloading, supplier / transporter shall deploy sufficient Labour for unloading the material at TPNODL central store. For heavy item(s), crane shall be arrange by the BA. However, in case, BA is not able to arrange the Crane, then TPNODL reserve the rights to hire the crane from market/ within internal resources and all expenditure/ unloading shall be recovered from BA.
9	The driver should have valid License and one helper in truck. All the documents of truck like registration papers, PUC etc. should be available in Truck.
10	BA representative should accompany the material and get it unloaded / stacked in his presence wherever possible.

13.0 GUARANTEE

13.1 Guarantee of Performance

Associates shall stand guarantee that the equipment and material supplied under the contract is free from design, manufacturing, material, construction, erection & installation and workmanship & quality defects and is capable of its due, rated and intended quality

Approved Copy of GCC (TPNODL)-Rev01

Doc. Title	GENERAL CONDITIONS OF CONTRACT FOR SUPPLY ORDERS	
Rev. No	01 dtd 01.12.2021	Page 16 of 47

performance, as an integrated product delivered under the contract, for a specific period termed as Guarantee Period(as elaborated elsewhere in this clause). The Associate should also guarantee that the equipment/material is new and unused except for the usage required for the tests and checks required as part of quality assurance.

13.2 Guarantee Period

The Guarantee Period will be equipment/service/work specific and shall be as specified in the Standard Specifications of TPNODL for the equipment/material/service/work and where standard specifications are not part of contract documents or guarantee period is not specified in the standard specifications,, the guarantee period shall be as per the Special Terms and Conditions of the Contract. In case of no mention of the guarantee period in standard specifications or SCC Guarantee Period will be 12 Months from the Date of Commissioning or 24 months from the date of delivery of final lot of supplies made, whichever is earlier.

13.3 Failure in Guarantee Period (GP)

If the equipment and material supplied under the contract fails to perform its due, rated & intended quality performance, during the Guarantee period, the associate is liable to undertake repair/rectify/replace the equipment and material supplied within time frame specified in the SCC or elsewhere in the contract documents at associate's cost to make the equipment and material supplied/service or work rendered under the contract of performing its due, rated and intended quality performance. If Associate fails to repair/rectify/replace the equipment or material supplied rendered under the contract, failed in Guarantee Period, TPNODL will be at liberty to get the same done at Associate's risks and costs and recover all such expenses plus the TPNODL's own charges (@ 20% of expenses incurred), from the Associate or from the "Security cum Performance Deposit" as the case may be.

If during the Warranty/ Guarantee period some parts of the supplies are replaced owing to the defects/ damages under the Warranty, the Warranty period for such replaced parts shall be until the expiry of twelve months from the date of such replacement or renewal or until the end of original Guarantee period, whichever is later.

Any repairs during the Guarantee Period shall be carried out by the Associate within 30 days of reporting the issue to Associate by TPNODL. However, if replacement of the Equipment is required, Associate shall notify the same to TPNODL within 7 days of reporting the issue by TPNODL. Thereafter, the total time for supply of new equipment/ material shall be equal to the original delivery period of that equipment/ material as specified in the Contract. In case the Associate is not able to rectify/ replace the faulty equipment/ material within the stipulated timelines as mentioned above, penalty shall be levied as per the Liquidated Damages clause mentioned in this document. The penalty amount shall be recovered from the payment due to the vendor or by encashment of the SPBG as the case may be.

13.4 Cost of repairs on failure in GP

The cost of repairs/rectification/replacement, required transportation, site inspection /mobilization/dismantling and re-installation costs as applicable, to be borne by Associate. The Associate has to ensure that the interruption in the usage of intended purpose of the equipment is minimized to the maximum extent In lieu of the time taken for repairs/rectification/replacement.

Doc. Title	GENERAL CONDITIONS OF CONTRACT FOR SUPPLY ORDERS	
Rev. No	01 dtd 01.12.2021	Page 17 of 47

13.5 Guarantee period for Goods Outsourced

If the Associate outsources partly equipment/materials/services from third party as mutually agreed upon at the pre award stage of contract, TPNODL shall have the benefit of any additional guarantee period if provided by the third party for the part supplied/executed by them.

13.6 Latent Defect

Hidden defects in manufacturing or design of the product supplied and which could not be identified by the tests conducted but later manifested during operation of the equipment are termed as latent defects. Associates shall further be responsible for 'free replacement' for another period of THREE years from the end of the guarantee period for any 'Latent Defects' if noticed and reported by the Company.

13.7 Support beyond the Guarantee Period

The Associate shall ensure availability of spares and necessary support for a period of atleast 10 years post completion of guarantee period of equipment supplied against the contract.

14.0 LIQUIDATED DAMAGES

- a) For supplies which are of standalone use, multiple in quantities and having a single final delivery schedule, Liquidated damages shall be levied without prejudice to any of the other contractual rights of TPNODL, as described below:

For delay of each week and part thereof from the delivery schedule specified in the contract, 1% of contract value corresponding to undelivered quantity, provided full quantity is supplied within 130% of the original contract time. If full contractual quantity is not delivered within 130% of contract time for delivery, TPNODL has the right to levy LD on the entire contract value, subject to a maximum of 10% of the total contract value.

- b) For Supplies having phased delivery schedule as per contract terms, standalone use and multiple in quantities, Liquidated damages shall be levied without prejudice to any of the other contractual rights of TPNODL, as described below:

For the purpose of calculating and applying LD, each delivery lot shall be considered separately. For delay of each week and part thereof, from the delivery schedule specified for the lot, 1% of the contract value corresponding to the undelivered quantity of the lot subject to a maximum of 10% of the total contract value of the subject lot. However, if full contractual quantity is not delivered within 130% of contract time for delivery, TPNODL has the right to levy LD on the entire contract value, subject to a maximum of 10% of the total contract value. Deduction of LD shall be on landed cost i.e contract value inclusive of taxes and in pursuant statutory compliance GST would be applicable at the stipulated rate and the same shall be borne by Business Associate. In case of LD deduction, a GST invoice shall be issued by TPNODL as a proof of deduction/ recovery.

14.1 LD Waiver Request

Any request of LD waiver shall be submitted within thirty (30) days of deducting LD. Request submitted beyond the timeline shall not be entertained.

15.0 UNLAWFUL ACTIVITIES

The Associate shall have to ensure that none of its employees are engaged in any unlawful activities (whether covered under the scope of the present GCC or not) subversive of the

Doc. Title	GENERAL CONDITIONS OF CONTRACT FOR SUPPLY ORDERS	
Rev. No	01 dtd 01.12.2021	Page 18 of 47

TPNODL's interest failing which appropriate action (legal or otherwise) may be taken against the Associate by the TPNODL, in accordance with the terms of the present GCC.

16.0 CONFIDENTIALITY

Associate and its employees or representatives thereof shall strictly maintain the confidentiality of various information they come across while executing the contract as detailed below.

16.1 Documents

All maps, plans, drawings, specifications, schemes and other documents or information related to the Contract/Project and the subject matter contained therein and all other information given to the Associate by the TPNODL in connection with the performance of the contract shall be held confidential by the Associate and shall remain the property of the TPNODL and shall not be used or disclosed to third parties by the Associate for any purpose other than for which they have been supplied or prepared. The Associate may disclose to third parties, upon execution of confidentiality agreements, such part of the drawings, specifications or information if such disclosure is necessary for the performance of the Work provided such third parties agree in writing to keep such information confidential to the same extent and degree as provided herein, for the benefit of the TPNODL.

16.2 Geographical Data

Maps, layouts and photographs of the unit/plant including its surrounding regions showing vital installation for national security of country or those of TPNODL shall not be published or disclosed to the third parties or taken out of the country without prior written approval of the TPNODL and upon execution of confidentiality agreements satisfactory to the TPNODL with such third parties prior to disclosure.

16.3 Associate's Processes

Title to secret processes if any developed by the Associate on an exclusive basis and employed in the design of the equipment shall remain with the Associate. TPNODL shall hold in confidence such processes and shall not disclose such processes to the third parties without prior approval of the Associate and execution by such third parties of secrecy agreements satisfactory to the Associate prior to disclosure. Upon completion of contract, such processes shall become the property of the TPNODL. Title to technical specifications, drawings, flow sheets, norms, calculations, diagrams, interpretations of test results, schematics, layouts and such other information, which the Associate has supplied to the TPNODL under the Contract shall be passed on to the TPNODL. The TPNODL shall have the right to use these for construction, erection, start-up, Trial Run, operation, maintenance, modifications and/or expansion of the works including for the manufacture of spare parts.

16.4 Exclusions

The provision of Clauses 16.1 to 16.3 shall not apply to information:

- Which at the time of disclosure are in the public domain which later on become part of public domain through no fault of the party concerned, or
- Which were in the possession of the party concerned prior to disclosure to him by the other party, or
- Which were received by the party concerned after the time of disclosure without restriction on disclosure or use, from a third party who did not acquire such information

Doc. Title	GENERAL CONDITIONS OF CONTRACT FOR SUPPLY ORDERS	
Rev. No	01 dtd 01.12.2021	Page 19 of 47

directly or indirectly from the other party or has no obligation of confidentiality for such information.

16.5 Violation

In case of violation of this clause, the Associate is liable to pay compensation and damages as may be determined by the competent authority of TPNODL.

17.0 INTELLECTUAL PROPERTY RIGHTS

If, in the course of performance of its functions and duties as envisaged by the scope of the present GCC, the Associate acquires or develops, any unique knowledge or information which would be covered, or, is likely to be covered within the definition of a trademark, copyright, patent, business secret, geographical indication or any other form of intellectual property right, it shall be obliged, under the terms of this present GCC, to share such knowledge or information with the TPNODL. All rights, with respect to, or arising from such intellectual property, as afore mentioned, shall solely vest in TPNODL.

Moreover, the Associate undertakes not to breach any intellectual property right vesting in a third party/parties, whether by breach of statutory provision, passing off, or otherwise. In the event of any such breach, the Associate shall be wholly liable to compensate, indemnify or make good any loss suffered by such third party/parties, or any compensation/damages arising from any legal proceeding/s, or otherwise. No liability of TPNODL shall arise in this respect, and any costs, damages, expenses, compensation payable by TPNODL in this regard to a third party/parties, arising from a legal proceeding/s or otherwise, shall be recoverable from the Associate.

18.0 INDEMNITY

The Associate shall at all times indemnify, keep indemnified and hold harmless the TPNODL and its officers, directors, employees, affiliates, agents, successors and assigns against all actions, claims, demands, costs, charges and expenses arising from or incurred by reason of any infringement of patent, trade mark, registered design, copy rights and/or industrial property rights by manufacture, sale or use of the equipment supplied by the Associate whether or not the TPNODL is held liable for by any court judgement. In this connection, the TPNODL shall pass on all claims made against him to the Associate for settlement.

The Associate assumes responsibility for and shall indemnify and save harmless the TPNODL from all liability, claims, costs, expenses, taxes and assessments including penalties, punitive damages, attorney's fees and court costs which are or may be required to be paid by the TPNODL and its officers, directors, employees, affiliates, agents, successors and assigns arising from any breach of the Associate's obligations under the Contract or for which the Associate has assumed responsibilities under the Contract including those imposed under any local or national law or laws, or in respect to all salaries, wages or other compensation for all persons employed by the Associate or his Sub-Associates or suppliers in connection with the performance of any work covered by the Contract. The Associate shall execute, deliver and shall cause his Sub-Associate and suppliers to execute and deliver, such other further instruments and to comply with all the requirements of such laws and regulation as may be necessary there under to conform and effectuate the Contract and to protect the TPNODL.

The TPNODL shall not be held responsible for any accident or damages incurred or claims arising, due to the Associate's error there from prior to completion of work. The Associate shall be liable for such accidents and after completion of work for such accidents as the case may be

Doc. Title	GENERAL CONDITIONS OF CONTRACT FOR SUPPLY ORDERS	
Rev. No	01 dtd 01.12.2021	Page 20 of 47

due to negligence on his part to carry out Work in accordance with Indian laws and regulations and the specifications set forth herein.

19.0 LIABILITY & LIMITATIONS

19.1 Liability

Except for any specific liability which may be identified in the Contract and which may be payable hereunder, Associate shall not be liable for any special, incidental, indirect, or consequential Damages or any loss of business Contracts, revenues or other financial loss (or equivalents thereof no matter how claimed, computed or characterized) arising out of or in connection with the Performance of the Work or supply of Goods ***unless caused by Associate's negligence, willful misconduct or breach of contract.***

If the Associate is a joint venture or consortium, all concerned parties shall be jointly and severally bound to the TPNODL for the fulfillment of the provisions of the Contract. The consortium or the joint venture shall designate one party as their leader, who will be the coordinator between the parties and TPNODL. The constituents & leader of the consortium or joint venture shall not be changed without the prior consent of TPNODL.

TPNODL shall have no liability or any special, incidental, indirect or consequential Damages for any loss of Business Contracts, revenues or other financial loss arising out of this Contract.

19.2 Limitation of Liability

The total liability of Associate against any contract shall be limited to the Total All Inclusive Contract Value.

20.0 FORCE MAJEURE

Force Majeure applies if the performance by either Party ("the Affected Party") of its obligations under Contract is materially and adversely affected.

"Force Majeure" shall mean any event or circumstance or combination of events or circumstances referred below and their consequences that wholly or partly prevents or unavoidably delays any Party in the performance of its obligations under this Agreement, but only and to the extent that such events and circumstances are not within the reasonable control, directly or indirectly, of the Affected Party and could not have been avoided even if the Affected Party had taken reasonable care:

- Act of war (whether declared or undeclared), invasion, armed conflict or act of foreign enemy, embargo, blockade, revolution, riot, bombs, religious strife or civil commotion, etc. ▪ Politically motivated sabotage, or terrorism, etc.
- Action or Act of Government or Governmental agency for which remedy is beyond the control of the affected parties. ▪ Any act of God.

Note: Causes like power breakdown/ shortages/fire/strikes, accidents etc do not fall under Force Majeure.

Time being the essence of the Contract, if either party is prevented from the performance of its obligations in whole or in part due to an event of Force Majeure, then provided Notice of happening of any event by the Affected Party is given to the other party within seven (7) days from the date of occurrence of such event, which DIRECTLY has impact on works and submitted details and quantum of resulting effect, but at the same time had made all possible efforts to mitigate and overcome effects thereof, the Affected Party's performance under this

Doc. Title	GENERAL CONDITIONS OF CONTRACT FOR SUPPLY ORDERS	
Rev. No	01 dtd 01.12.2021	Page 21 of 47

Contract shall be suspended until such event ceases and the Scheduled Completion shall be delayed accordingly.

If Force Majeure event(s) continue for a period of more than three months, the parties shall hold consultation to discuss the further course of action.

Neither party shall be considered to be in default or in breach of its obligation under the Contract to the extent that performance of such obligation by either party is prevented by any circumstances of Force Majeure which arise after effective date of Contract.

Neither party can claim any compensation from the other party on account of Force Majeure.

21.0 SUSPENSION OF CONTRACT

21.1 Suspension for Convenience

TPNODL may, at any time and at its sole option, suspend execution of all or any portions of the schedule of items of contract to be supplied/work to be executed by Associate under the contract by providing to the Associate at least two business days written notice for contracts having contract completion period less than sixty days and at least seven business days' notice for all other contracts.

Upon receipt of any such notice, the Associate shall respond as follows as applicable as per contract construction.

- Immediately discontinue further supply of material/goods specified in the suspension notice for supply contracts
- Immediately discontinue further service/work and supply of materials of those services/materials/work specified in the suspension notice for service /composite contract
- Promptly make every reasonable effort to obtain suspension, upon terms satisfactory to TPNODL, of all orders, outsourcing arrangements, and rental Contracts to the extent that they relate to performance of the portion of Work suspended by the notice.
- Protect and maintain the portion of the service/Work already completed, including the portion of the Work suspended hereunder, unless otherwise specifically stated in the notice.
- Continue delivering/carrying out the supply/service/work items as per contract conditions, which do not fall under purview of the suspension notice.

On receipt of resumption notice from TPNODL, the Associate shall resume execution of contract as specified in the resumption notice, within the time frame specified in the resumption notice.

21.2 Suspension for Breach of Contract conditions.

TPNODL shall suspend execution of whole/or part thereof the contract till such time Associate complies with the conditions stipulated under section clause 22.1 for breach/default of contract conditions.

21.3 Compensation in lieu of Suspension

If the suspension of the contract in whole or in part is for convenience of TPNODL and not due to any breach of contract conditions by the associate, TPNODL at its discretion shall consider compensating all reasonable additional costs incurred by Associate in lieu of suspension of

Doc. Title	GENERAL CONDITIONS OF CONTRACT FOR SUPPLY ORDERS	
Rev. No	01 dtd 01.12.2021	Page 22 of 47

whole or part of contract, on representation of the Associate providing justified estimates of such additional costs and such estimates are found acceptable and approved by competent authority of TPNODL.

If the suspension of contract in whole or part thereof is due to breach of contract conditions (refer clause 22.1) by the Associate, Associate shall not be entitled for any compensation for any cost incurred in lieu of suspension of whole or part of contract and also shall be liable for compensating all the losses arising to TPNODL in lieu of suspension of contract. Resumption notice shall be subject to the Associate taking corrective action for the breach of contract conditions within the time frame and as per the terms specified in the suspension notice.

22 TERMINATION OF CONTRACT

22.1 Termination for Default/Breach of Contract

The contract / PO /RC shall be subject to termination by TPNODL in case of breach of the contract by the Associate which shall include but not be limited to the following:

- a. Withdrawal or intimation by the Associate of its intent to withdraw or surrender the execution / completion of the contracted work /PO or failure in ensuring adherence to any delivery schedules, in deviation of the contract/PO.
- b. Refusal or neglect on the part of the Associate to supply material/equipment of quantity or quality as specified by TPNODL and within the timeframe as specified in the contract document or refusal or neglect to execute the services/work in terms of the agreed standards of quantity or quality and/or within the timeframe specified in the contract/PO.
- c. Failure in any respect to perform any portion of the Work contracted with promptness, diligence, or in accordance with the terms of the contract.
- d. Failure to furnish guarantees as specified and /or failure to comply with the terms thereof.
- e. Failure to furnish such relevant documents or information within the time specified which may be necessary for due execution / completion of the works and documentation.
- f. Liquidation, bankruptcy either voluntary or involuntary OR entering into any composition or compromise with its creditors, or Insolvency.
- g. In case any reasonable information has been received by TPNODL that Associate has adopted/ or attempted to adopt any unethical conduct, action in award of the contract /PO or at any time thereafter.
- h. Failure to comply with applicable statutory provisions as contained in the contract or failure to comply with the applicable laws.
- i. Failure to comply with safety regulations/clauses stipulated in the contract or as may be generally instructed by TPNODL.

If the default or breach as specified under clause 22 (except sub clause g thereof) be committed by the associate for the first time, TPNODL shall issue, along the with notice of default or breach, a warning notice instructing the associate to take remedial/corrective action within the time frame stipulated in the warning notice and not to repeat the same in future. The timeframe for corrective action by the associate shall be specific to the nature of breach of contract and the same shall not be objected to by the Associate. If the Associate fails to comply with the instructions in the warning notice or in taking corrective action to the satisfaction of

Doc. Title	GENERAL CONDITIONS OF CONTRACT FOR SUPPLY ORDERS	
Rev. No	01 dtd 01.12.2021	Page 23 of 47

TPNODL then TPNODL may terminate the entire or part of contract at its discretion by issuing termination notice without incurring any liability on this ground.

In case the contract is terminated for any breach of the nature specified in clause 22 g stated above, TPNODL shall have the right to terminate all the contracts TPNODL is having with the Associate by issuing termination notice which shall be without prejudice to the other rights of TPNODL available to it under law.

Without prejudice to its right to terminate for breach of contract, TPNODL may, without assigning any reason, terminate the Contract in whole or in part at any time at its discretion while the contract is in force by serving a written notice of two weeks to the Associate.

In the event of TPNODL having proceeded with termination of the contract the associate shall comply and proceed further in the following manner:

- a) Associate shall discontinue the supply, on the expiry of the said period of two weeks.
- b) Associate shall ensure that no further steps are being taken towards discharge of the obligations, terms and conditions as contained in the contract/PO. This shall include initiation of actions not limited to discontinuation of other allied and associated arrangements which the associate might have entered into with third parties for due discharge of its obligations under the contract with TPNODL.
- c) The Associate shall perform thereafter such tasks as may be necessary to preserve and protect the terminated portion of the material/service/work in progress and the materials and equipment at TPNODL sites or in transit thereto. However the associate shall continue to fulfill its contractual obligations with regard to the part of contract not terminated.
- d) It shall be open for TPNODL to conduct a joint assessment with the associate of the material, supplies, equipment, works or in general as to the subject matter of the contract in regard to which the associate claims having completed its obligations before or during such termination.
- e) It shall be open to TPNODL to seek invocation of the performance bank guarantee or any other guarantee or other security deposit by whatever name called submitted by the associate, which shall not be objected to or protested against by the associate.

In case of termination of the contract the parties agree to be governed inter alia by the following:

- a) In case TPNODL exercises its right of termination as stated above the associate shall not dispute or object to the same.
- b) The Associate shall be entitled to receive and claim only such payments OR sums of money from TPNODL as may be found payable to it in regard to works executed by it under the terms of the contract and no other claim of any nature whatsoever shall be made by the Associate.
- c) All such provisions which the parties have agreed to survive and prevail even after termination of the contract shall remain effective despite the termination.

In the event of such termination, TPNODL may finish the Work by whatever method it may deem expedient, including the hiring of services and /or purchase of material equipment from such third parties as TPNODL may deem fit or may itself provide any labor or materials and

Doc. Title	GENERAL CONDITIONS OF CONTRACT FOR SUPPLY ORDERS	
Rev. No	01 dtd 01.12.2021	Page 24 of 47

perform any part of the Work. The associate undertakes to bear the incremental costs if any paid by TPNODL in such a case attributable to failure on the part of the associate. The Associate in such a case shall not be entitled to receive any further payments and any sums found payable to it may be adjusted by TPNODL against the amount recoverable from him on this ground. The same shall be without prejudice to other rights available to TPNODL under law against the associate.

Upon the termination of any of the contract due to occurrence of any circumstances provided in clauses stated above and constituting repeated breach or misconduct, TPNODL shall be entitled to bar the associates its agents, affiliates from undertaking any negotiation / tendering, bidding, participation activities concerning TPNODL for a period of two years from date of such termination. The same shall be without prejudice to other rights available to TPNODL.

22.2 Termination for Convenience of Associate

Associate at its convenience may request for termination of contract, clearly assigning the reason for such request. TPNODL has full right to accept, reject or partially accept such request. However, associate shall continue its supply as per contract till final approval is given to associates for such termination.

22.3 Termination for Convenience of TPNODL

TPNODL at its sole discretion may terminate the contract by giving 30 days prior notice in writing or through email to the Associate. TPNODL shall pay the Associate for all the supplies/ services rendered till the actual date of contract termination against submission of invoice by the Associate to that effect.

23.0 DISPUTE RESOLUTION & ARBITRATION

In case of any dispute or difference the parties shall endeavour to resolve the same through conciliatory and amicable measures within 15 Days failing which the matter may be referred by either party for resolution by the sole arbitrator to be appointed mutually by both the parties. The arbitral proceedings shall be conducted in accordance with Arbitration and Conciliation Act 1996 and the place of arbitration shall be Bhubaneswar. The language to be used at proceedings shall be English and the award of the arbitrator shall be final and binding on the parties. The parties shall bear their respective costs of arbitration. The associate shall continue to discharge its obligations towards due performance of the works as per the terms of the contract during the arbitration proceedings unless otherwise directed in writing by TPNODL or suspended by the arbitrator. Further, TPNODL shall continue making such payments as may be found due and payable to the associate for such works.

23.1 Governing Laws and Jurisdiction

The parties shall be subject to the jurisdiction of the courts of law in Bhubaneswar and any matter arising here from shall be subject to applicable law in force in India.

24.0 ATTRIBUTES OF GCC

24.1 Cancellation

The Company reserves the right to cancel, add, delete at its sole discretion, all or any terms of this GCC or any contract, order or terms agreed between the parties in pursuance without assigning any reasons and without any compensation to the Associates.

Doc. Title	GENERAL CONDITIONS OF CONTRACT FOR SUPPLY ORDERS	
Rev. No	01 dtd 01.12.2021	Page 25 of 47

24.2 Severability

If any portion of this GCC is held to be void, invalid, or otherwise unenforceable, in whole or part, the remaining portions of this GCC shall remain in effect.

24.3 Order of Priority

In case of any discrepancies between the stipulations in General Conditions of the Contract (GCC) and Special Conditions of Contract (SCC), the GCC shall stand superseded by the SCC to the extent stipulated hereinabove while balance portion of respective clauses of GCC shall continue to be applicable.

25.0 ERRORS AND OMISSIONS

The Associate shall be responsible for all discrepancies, errors and omissions in the drawings, documents or other information submitted by him, irrespective of whether these have been approved, reviewed or otherwise accepted by the TPNODL or not. However any error in design/drawing arising out of any incorrect data/written information from TPNODL will not be considered as error and omissions on part of the Associate.

26.0 TRANSFER OF TITLES

The title of ownership and property to all equipment, materials, drawings & documents shall pass to the TPNODL on acceptance of material by store/site after Inspection.

However, such passing of title of ownership and property to the TPNODL shall not in any way absolve, dilute or diminish the responsibility and obligations of the Associate under this Contract including loss or damages and all risks, which shall vest with the Associate.

27.0 INSURANCE

The Contractor shall take out the Insurance Policies which shall cover all risks including the following, as applicable:-

- a) The value of the policy shall cover the total value of all the items till they are handed over to TPNODL.
- b) TPNODL shall be the principal holder of the policy. The Associate shall be the loss payee under the policy. Associate / Sub-contractor of the Associate shall not be holders or beneficiaries in the policy nor shall they be named in the policy. TPNODL reserves the exclusive right to assign the policy.
- c) While the payment of premium may be phased in agreement with the insurance company, at no time shall goods and services required to be provided by the associate shall remain uninsured in accordance with (a) above.
- d) A copy of the Insurance policy shall be made available to TPNODL prior to first dispatch lot of any Equipment and policy shall be kept alive and valid at all times up to the stage of final acceptance.
- e) TPNODL reserves the right to take out whatever policy that is deemed necessary by him if the associate fails to keep the said policy alive and valid at all times and/or causes lapses in payment of premium thereby jeopardizing the said policy. The cost of such policy(s) shall be recovered / deducted from the amount payable to the associate.

Doc. Title	GENERAL CONDITIONS OF CONTRACT FOR SUPPLY ORDERS	
Rev. No	01 dtd 01.12.2021	Page 26 of 47

- f) The policy shall ensure that the TPNODL's decision regarding replacement of goods damaged, lost or rendered unusable shall be final.

In all cases, the associate shall lodge the claims with the underwriters and also settle the claims and shall also notify TPNODL of any filed claims. However, the associate shall proceed with the repairs and/or replacement of the equipment/components without waiting for the settlement of the claims. In case of seizure of materials by concerned authorities, the associate shall arrange prompt release against bond, security or cash as required. TPNODL, upon request by the associate, will extend all reasonable assistance to the associate in such a case.

All the insurance claims shall be processed and settled by the associate and the missing/damaged items shall be replaced/repared by them without any extra cost to TPNODL and without affecting the completion time.

28.0 SUGGESTIONS & FEEDBACK

We welcome all our Business Associates to write to us about their experience with TPNODL; be it our Company, our services or our people. Each and every concern, issue, query and suggestion from you will help us to become a better company to work with and shall help us develop a strong bonding of trust and a long term relationship with you.

You may send your feedback to HOD Contracts by filling up our Business Associate Feedback Form enclosed herewith as *Annexure-I*.

29.0 CONTACT POINTS

In case Business Associate needs information with respect to payments or has any grievances, he may contact to HoD-Contracts and Finance.

30.0 LIST OF ANNEXURES

S. No.	Subject	Annexure
1.	Performa for Bid Security Bank Guarantee	A
2.	Performa for Performance Bank Guarantee (CP cum EP)	B
3.	Performa for No Demand Certificate by Associate	C
4.	Performa For Application For Issuance of Consolidated TDS Certificate	D
5.	Business Associate Feedback Form	E
6.	Acceptance Form For Participation In Reverse Auction Event	F
7.	Form for RTGS Payment	G
8.	Vendor Appraisal Form	H
9.	Manufacturer Authorization Form	I
10.	Tata Code of Conduct	I

ANNEXURE-A

Doc. Title	GENERAL CONDITIONS OF CONTRACT FOR SUPPLY ORDERS	
Rev. No	01 dtd 01.12.2021	Page 27 of 47

PROFORMA FOR BID SECURITY BANK GUARANTEE

**TP Northern Odisha Distribution Limited
Balasore**

WHEREAS, (Name of the Bidder) _____
(hereinafter called "the BIDDER") has submitted his bid dated _____ for the
(Tender No. & Name of Contract) _____ (hereinafter
called "the BID").

KNOW ALL men by these presents we (Name of the
Bank) _____ of (Name of the
Country) _____ having our registered
office at _____ (hereinafter called "the BANK) are bound unto
TPNODL in the sum of _____ for which payment well and truly to be
made to the TPNODL the Bank binds himself, his successors and assigns by these
presents.

SEALED with the Common Seal of the said Bank this _____ day of _____ 20_____.

The CONDITIONS of this obligation are:

- i) If the Bidder withdraws his Bid during the period of bid validity specified in the Proforma of Bid or
- ii) If the Bidder having been notified of the acceptance of his Bid by the TPNODL during the period of bid validity fails or refuses to furnish the Contract Performance Bank Guarantee, in accordance with the Instructions to Bidders.

We undertake to pay the TPNODL upto the above amount upon receipt of its first written demand, provided that in its demand the TPNODL will note that amount claimed by it is due to it owing to the occurrence of one or both conditions, specifying the occurred condition or conditions.

This Guarantee will remain in force upto and including the date (No of days as mentioned in tender enquiry) days after the closing date of submission of bids as stated in the Invitation to Bid or as extended by you at any time prior to this date, notice of which extension to the Bank being hereby waived, and any demand in respect thereof should reach the Bank not later than the above date.

DATE	SIGNATURE OF THE BANK
WITNESS	SEAL

(Signature, Name & Address) (At least 2 witnesses)

ANNEXURE- B

PROFORMA FOR PERFORMANCE BANK GUARANTEE (CP cum EP)

(On Rs.100/- Stamp Paper) Note:

- a) Format shall be followed in toto
- b) Claim period of six months must be kept up

Doc. Title	GENERAL CONDITIONS OF CONTRACT FOR SUPPLY ORDERS	
Rev. No	01 dtd 01.12.2021	Page 28 of 47

- c) The guarantee to be accompanied by the covering letter from the bank confirming the signature to the guarantee

TP Northern Odisha Distribution Ltd.

Balasore

CP cum EP BG No.....

Order/Contract No.....dated.....

1. You have entered into a Contract No _____ with M/s. _____ (hereinafter referred to as "the Vendor") for the supply cum erection / civil work of _____ (hereinafter referred to as "the said Equipment") for the price and on the terms and conditions contained in the said contract.
2. In accordance with the terms of the said contract, "the Vendor" agreed to furnish you with an irrevocable, unconditional and acceptable bank guarantee for 10% of the value of contract and to be valid till the end of Guarantee period plus one month towards "Contract cum Equipment performance". For this purpose you have agreed to accept the guarantee.
3. In consideration thereof, we, _____ hereby irrevocably and unconditionally guarantee to pay to you on demand but in any case before the end of five working days from the date of the claim and without demur and without reference to "the Vendor" such amount or amounts not exceeding the sum of Rs. _____ (Rupees _____ only) being _____% (_____ percent) of the total value of the contract on receipt of your intimating that "the Vendor" has not fulfilled his contractual obligations. You shall be the sole judge for such non-fulfillment and "the Vendor" shall have no right to question such judgment.
4. You shall have the right to file / make your claim on us under the guarantee for a **further period of one month** from the date of expiry.
5. This guarantee shall not be revoked without express consent and shall not be affected by your granting time or any other indulgence to "the Vendor", which shall include but not be limited to, postponement from time to time of the exercise the same in you or any right which you may have against "the Vendor" and to exercise the same in any covenant contained or implied in the said contract or any other course or remedy or security available to you, and our Bank shall not be released from its obligations under this guarantee by

Doc. Title	GENERAL CONDITIONS OF CONTRACT FOR SUPPLY ORDERS	
Rev. No	0	Page 29 of 47

your exercising any of your rights with reference to matters aforesaid or any of them or by reasons of any other act or forbearance or other acts of omission or commission on your part or any other indulgence shown by you or by any other matter or thing whatsoever which under the law would, but for this provision have the effect of relieving our bank from its obligation under this guarantee.

6. We also agree that you shall be entitled at your option to enforce this guarantee against our bank as a principal debtor, in the first instance, notwithstanding any other security or guarantee that you may have in relation to "the Vendor's" liabilities in respect of the premises
7. This guarantee shall not be affected by any change in the constitution of our Bank or "the Vendor" or for any other reason whatsoever.
8. Any claim / extension under the guarantee can be lodge-able at outstation banks or at Balasore branch and claim will also be payable at Balasore Branch (to be confirmed by Balasore Branch by a letter to that effect in case BG is from the branch outside Balasore).
9. Notwithstanding anything herein contained, our liability under this guarantee is limited to Rs. _____ (Rupees _____) only and the guarantee will remain in force upto and including _____ (Date) and shall be extended from time to time for such period or period as may be desired by "the Vendor".
10. Unless a demand or claim under this guarantee is received by us in writing within six months from _____ (expiry date) i.e. on or before _____ (claim period end date), we shall be discharged from all liabilities under this guarantee thereafter.

Dated at _____ this _____ day of _____ 20__

Bank's rubber stamp

1. Banks full address

Designation of Signatory

2. Bank official number

Doc. Title	GENERAL CONDITIONS OF CONTRACT FOR SUPPLY ORDERS	
Rev. No	0	Page 30 of 47

ANNEXURE-C

PROFORMA FOR “NO DEMAND CERTIFICATE” BY ASSOCIATE

(On Company's Letter head or with Company Seal)

(To be submitted by the Associate to TPNODL Accounts Department at the time of receipt of full and final payment)

(Certificate No. CCP/002)

Name of the Project Order/

Contract No.

Dated

Name of the Associate Scheme

No. / Job No.

We, M/s. _____ (Associate) do hereby acknowledge and confirm that we have received the full and final payment due and payable to us from TPNODL, in respect of our aforesaid Order No _____ dated _____ including amendments, if any, issued by TPNODL to our entire satisfaction and we further confirm that we have no claim whatsoever pending with TPNODL under the said contract / W.O.

Notwithstanding any protest recorded by us in any correspondence, documents, measurement books and / or final bills etc., we waive all our rights to lodge any claim or protest in future under this contract.

We are issuing this “NO DEMAND CERTIFICATE” in favour of TPNODL, with full knowledge and with our free consent without any undue influence, misrepresentation, coercion etc.

Place

Name

(Company Seal)

Doc. Title	GENERAL CONDITIONS OF CONTRACT FOR SUPPLY ORDERS	
Rev. No	0	Page 31 of 47

ANNEXURE-D

**PROFORMA FOR APPLICATION FOR ISSUANCE OF CONSOLIDATED TDS
CERTIFICATE**

To be printed on the letterhead

To,
TPNODL,
Balasore

Sub: Application for issuance of Consolidated TDS Certificate for the FY _____

Dear Sir,

I / we hereby request / authorize you to issue me / us a consolidate TDS Certificate for the financial year _____ against tax deducted at source by you from my / our payments / bills during the said year from time to time under Chapter XVII – B of the Income Tax Act, 1961. For and on behalf of

Signature

Name

Address

Contact No. (Land Line)
(Mobile)

PAN #

Assessing authority

ATTACH THE COPY OF PAN CARD

Doc. Title	GENERAL CONDITIONS OF CONTRACT FOR SUPPLY ORDERS	
Rev. No	0	Page 32 of 47

ANNEXURE-E

BUSINESS ASSOCIATE FEEDBACK FORM

With an objective to improve our internal processes and systems, and serve you better, we solicit your valuable feedback & suggestions. It is estimated that it will take about 10 minutes to complete this survey. We assure you that your feedback shall be kept confidential. Please send the duly filled feedback form in the "TPNODL addressed - attached envelop"

You are associated with us as

- OEMs Service Contractor Material Suppliers Material & Manpower Supplier

You are associated with us for

- Less than 1 year More than 1 year but less than 3 years More than 3 years

Your office is located at

- Balsore Within 200 kms from Balsore More than 200 kms from Balsore

Your nearly turnover with TPNODL

- Less than 25 Lacs 25 Lacs to 1 Crore More than 1 Cr.

Additional Information

Your Name	
Your Designation	
Your Organization	
Contact Nos.	
Email	

We once again thank you for your participation in this survey. Please spare 10 minutes to give your feedback on following pages (Section A to E)

SECTION – A

(Please ✓ mark in the relevant box and give your remarks / suggestions / information for our improvement).

S. No.	Parameters	1	2	3	4	5	Remarks/ Suggestion
		Do Not Agree	Slightly in Agreement	In Fair Agreement	Mostly in Agreement	Fully Agree	
1	You receive all relevant queries / tenders from us in timely manner.						
2	We provide you enough lead time to respond to our queries / tenders.						
3	We provide you adequate support (drawings, documents, clarifications, briefing etc.) to enable you meet our requirements.						
4	All following elements of our contract / purchase order are rational :						
4.1	Scope of Work						
4.2	Delivery / Execution Schedule						
4.3	Payment Terms						
4.4	Liquidated Damages						
4.5	Performance Guarantee						
5	Our purchase orders / contracts are simple, specific & easy to understand						
6	TPNODL demonstrate willingness to be flexible in administration of Contract / Purchase Order						
7	We provide timely responses / clarifications to your queries						
8	TPNODL representative you interact / coordinate with is adequately empowered to support you in meeting contractual obligations						
9	TPNODL provide you all necessary infrastructure support for timely and quality completion of work (including AMC)						
10	TPNODL Engineer-in-Charge timely certifies the jobs executed/ material supplied						
11	TPNODL Engineer-in-Charge efficiently supervises the job execution for timely completion of job						
12	BIRD (Bill Inward Receipt Desk) initiative has improved payment disbursement process						

S. No.	Parameters	1	2	3	4	5	Remarks/ Suggestion
		Do Not Agree	Slightly in Agreement	In Fair Agreement	Mostly in Agreement	Fully Agree	
13	Our approach for Inspection and Quality Assurance effective to expedite project completion?						
14	TPNODL never defaults on contractual terms						
15	In TPNODL Contracts closure is done within set time limit						
16	Our material receiving procedures are well defined and efficiently deployed to reduce mutual inconvenience						
17	Bank Guarantees are released in time bound manner						
18	Our processes related to payment / account settlement are effective.						
19	You get payments on time						
20	TPNODL Employees follow Ethical behaviour						

GENERAL CONDITIONS OF CONTRACT

SECTION – B

SECTION – B (Please rate the following parameters on a scale of 1 to 5, where 1 - Minimum; 5 - Maximum)

S. No.	Parameters	1	2	3	4	5	Remarks/ Suggestion
1	How do you rate courtesy/ empathy/ attitude level and warmth of TPNODL employees you interact with from following team?						
1.1	Project Engineering						
1.2	District / Zones						
1.3	Projects/HOG (TS &P)						
1.4	Inspection & Quality Assurance						
1.5	Stores						
1.6	Metering & Billing						
1.7	Accounts / Finance						
1.8	Administration						
1.9	IT & Automation						
2	How would you rate TPNODL in comparison to your other clients in terms of fairness of treatment and transparency with its Business Associates?						
3	How would you rate TPNODL in comparison to your other clients in terms of processes and systems to manage partnership with its Business Associates						
4	How would you rate TPNODL in comparison to your other clients in terms of building long term & mutually relationship with its Business Associates						

SECTION – C

Please √ mark in the relevant box and give your remarks / suggestions / information for our improvement.

S. No.	Parameters	Certainly No	Probably No	Certainly Yes	Probably Yes	Remarks/ Suggestion
1	Based on your experience with TPNODL, would you like to continue your relationship with TPNODL?					
2	If someone asks you about TPNODL, would you talk “positively” about					

	TPNODL?					
3	Would you refer TPNODL name to others in your community, fraternity and society as a professional & dynamic organization?					

SECTION - D

If we ask you to rate us on a scale of 1 to 10, how will you rate TPNODL, that truly represents your overall satisfaction with us (please tick appropriate box) -

1	2	3	4	5	6	7	8	9	10
---	---	---	---	---	---	---	---	---	----

SECTION - E

Please ✓ mark in the relevant box and give your remarks / suggestions / information for our improvement.

Please spare your thoughts for TPNODL's improvement in particular areas of weaknesses, particularly relating to some great practices, attitudes that you have seen elsewhere in Indian and International Organizations, which you recommend TPNODL to adopt. Please give your valuable salient recommendations.

Please spare your thoughts for TPNODL's improvement in particular areas of major concerns for you. We also welcome your suggestions to adopt any best practices, attitudes that you

Recommendation	<i>Please tick (✓) your top 5 expectations out of the following 10 points listed below -</i>	
(Please list down improvement you expect from TPNODL)	<i>Timely payment</i>	
1	<i>Flexibility in Contracts/PO</i>	
	<i>Clarity in PO,s & Contracts</i>	
2	<i>Timely response to quarries</i>	
	<i>Timely certification of works executed</i>	
3	<i>Clarity in Specs, drawings, other docs etc.</i>	
	<i>Adequate information provided on website for tender notification, parties qualified etc.</i>	
4	<i>Timely receipt of material at site for execution</i>	
	<i>Performance Guarantee/EMD released in time</i>	

Doc. Title	GENERAL CONDITIONS OF CONTRACT FOR SUPPLY ORDERS	
Rev. No	0	Page 37 of 47

5	<i>Inspection & quality assurance support for timely job completion</i>
---	---

We thank you for your time and courtesy!!

ANNEXURE-F

ACCEPTANCE FORM FOR PARTICIPATION IN REVERSE AUCTION EVENT

(To be signed and stamped by the bidder prior to participation in the auction event)

In a bid to make our entire procurement process more fair and transparent, TPNODL intends to use the reverse auctions through ARIBA tool as an integral part of the entire tendering process. All the bidders who are found as technically qualified based on the tender requirements shall be eligible to participate in the reverse auction event.

The following terms and conditions are deemed as accepted by the bidder on participation in the bid event:

1. TPNODL shall provide the user id and password to the authorized representative of the bidder. (Authorization Letter in lieu of the same shall be submitted along with the signed and stamped Acceptance Form).
2. TPNODL will make every effort to make the bid process transparent. However, the award decision by TPNODL would be final and binding on the supplier.
3. The bidder agrees to non-disclosure of trade information regarding the purchase, identity of TPNODL, bid process, bid technology, bid documentation and bid details.
4. The bidder is advised to understand the auto bid process to safeguard themselves against any possibility of non-participation in the auction event.
5. In case of bidding through Internet medium, bidders are further advised to ensure availability of the entire infrastructure as required at their end to participate in the auction event. Inability to bid due to telephone line glitch, internet response issues, software or hardware hangs, power failure or any other reason shall not be the responsibility of TPNODL.
6. In case of intranet medium, TPNODL shall provide the infrastructure to bidders. Further, TPNODL has sole discretion to extend or restart the auction event in case of any glitches in infrastructure observed which has restricted the bidders to submit the bids to ensure fair & transparent competitive bidding. In case an auction event is restarted, the best bid as already available in the system shall become the start price for the new auction.
7. In case the bidder fails to participate in the auction event due any reason whatsoever, it shall be presumed that the bidder has no further discounts to offer and the initial bid as submitted by the bidder as a part of the tender shall be considered as the bidder's final no regret offer. Any offline price bids received from a bidder in lieu of non-participation in the auction event shall be out rightly rejected by TPNODL.
8. The bidder shall be prepared with competitive price quotes on the day of the bidding event.
9. The prices as quoted by the bidder during the auction event shall be inclusive of all the applicable taxes, duties and levies and shall be FOR at TPNODL site.
10. The prices submitted by a bidder during the auction event shall be binding on the bidder.
11. No requests for time extension of the auction event shall be considered by TPNODL.
12. The original price bids of the bidders shall be reduced on pro-rata basis against each line item based on the final all inclusive prices offered during conclusion of the auction event for arriving at Contract amount.

Signature & Seal of the Bidder

Doc. Title	GENERAL CONDITIONS OF CONTRACT FOR SUPPLY ORDERS	
Rev. No		Page 39 of 47

Name of the Authorized Signatory: _____ :

Contact Person's Name:

Official Correspondence Address:

We confirm that we will bear the charges, if any, levied by our bank for the credit of NEFT/RTGS amounts in our account. Any change in above furnished information shall be informed to TPNODL well in time at our own. Further, we kept TPNODL indemnified for any loss incurred due to wrong furnishing of above information.

Thanking you,

For _____

(Authorised Signatory)

(Signature with Rubber Stamp)

Certification from Bank:

We confirm that we are enabled for receiving NEFT/RTGS credits and we further confirm that the account number (specify Bank a/c no.) of (Please mention here name of the account holder), the signature of the authorised signatory and the MICR and IFSC Code of our branch mentioned above are correct.

This also is certified that the above information is correct as per Bank record

(Manager's/ Officers Signature under Bank Stamp)

Doc. Title	GENERAL CONDITIONS OF CONTRACT FOR SUPPLY ORDERS	
Rev. No		Page 40 of 47

ANNEXURE-H
VENDOR APPRAISAL FORM

TO BE SUBMITTED BY VENDOR (To be filled as applicable)		
Part A		
1.0	DETAILS OF THE FIRM	
	1.1	NAME (IN CAPITAL LETTERS)
	1.2	TYPE OF CONCERN (PROPRIETARY) PARTNERSHIP PVT.LTD., PUBLIC LTD. ETC.
	1.3	YEAR OF ESTABLISHMENT
	1.4	LOCATION OF OFFICE POSTAL ADDRESS
	1.5	CONTACT DETAIL OF BA's REPRESENTATIVE NAME E-MAIL ID CELL NO.
	1.6	LOCATION OF MANUFACTURING UNITS
		i) UNITS 1
		ii) OTHER UNITS
2.0	PRODUCTS / SERVICES BEING OFFERED	
3.0	TURNOVER DURING THE LAST 3 YEARS (TO BE VERIFIED WITH THE LATEST PROFIT & LOSS STATEMENT).	
4.0	AVAILABILITY OF STATUTORY DOCUMENTS I.E. COPY OF PAN CARD	
5.0	AVAILABILITY OF STATUTORY DOCUMENTS I.E. COPY OF GST REGISTRATION	
6.0	APPLICABILITY UNDER MSME CERTIFICATION	
7.0	BA BELONGS TO AA COMMUNITY (SC/ST)	
8.0	DOCUMENTS VERIFYING ADDRESS PROOF (SUPPORTED BY ANY GOVT. ISSUED DOCUMENT)	

9.0	TECHNICAL		
	9.1	NO.OF DESIGN ENGINEERS (INDICATE NO.OF YEARS EXPERIENCE IN RELATED FIELDS)	:
	9.2	NO.OF DRAUGHTSMEN	:
	9.3	COLLABORATION DETAILS (IF ANY)	:
		9.3.1 DATE OF COLLABORATION	:
		9.3.2 NAME OF COLLABORATOR	:
		9.3.3 RBI APPROVAL DETAILS	:
		9.3.4 EXPERIENCE LIST OF COLLABORATOR	:
		9.3.5 DURATION OF AGREEMENT	:
	9.4	AVAILABILITY OF STANDARDS / DESIGN PROCEDURES / COLLABORATOR'S / DOCUMENTS (CHECK WHETHER THESE ARE LATEST/CURRENT)	:
	9.5	TECHNICAL SUPPORT, BACK-UP GUARANTEE, SUPERVISION, QUALITY CONTROL BY COLLABORATOR (WHEREVER ESSENTIAL). (THIS CLAUSE IS RELEVANT WHEN VENDOR'S EXPERIENCE IS INADEQUATE)	:
	9.6	QUALITY OF DRAWINGS	:
10.0	MANUFACTURE		
	10.1	SHOP SPACE, LAYOUT LIGHTING, VENTILATION, ETC.	:
	10.2	POWER (KVA)	:
		MAINS INSTALLED	:
		UTILISED	:
		STANDBY POWER SOURCE	:
	10.3	MANUFACTURING FACILITIES (ATTACH LIST OF EQUIPMENTS AS APPLICABLE)	:
		10.3.1 MATERIAL HANDLING	:
		10.3.2 MACHINING	:
		10.3.3 FABRICATION	:

Doc. Title	GENERAL CONDITIONS OF CONTRACT FOR SUPPLY ORDERS	
Rev. No		Page 42 of 47

		10.3.4 HEAT TREATMENT	:
		10.3.5 BALANCING FACILITY	:
		10.3.6 SURFACE TREATMENT PRIOR TO PAINTING/ COATING, POLISHING, PICKLING, PASSIVATION, PAINTING, ETC.	:
	10.4	SUPERVISORY STAFF	:
	10.5	ADEQUACY OF SKILLED LABOURS (MACHINISTS, WELDERS, ETC.)	:
	10.6	NO. OF SHIFTS	:
	10.7	TYPE OF MATERIAL HANDLED (SUCH AS CS, SS, ETC.)	:
	10.8	WORKMANSHIP	:
	10.9	MATERIAL IN STOCK AND VALUE	:
	10.10	TRANSPORT FACILITIES	:
	10.11	CARE IN HANDLING	:
11.0	INSPECTION / QC / QA / TESTING		
	11.1	NUMBER OF PERSONNEL (INDICATE NO.OF YEARS OF EXPERIENCE)	:
	11.2	INDEPENDENCE FROM PRODUCTION	:
	11.3	AVAILABILITY OF PROCEDURAL WRITE UP/QUALITY PLAN	:
	11.4	INCOMING MATERIAL CONTROL AND DOCUMENTATION	:
	11.5	RELIABILITY/REPUTATION OF SUPPLY SOURCES	:
	11.6	STAGE INSPECTION AND DOCUMENTATION	:
	11.7	SUB-ASSEMBLY & DOCUMENTATION	:
	11.8	FINAL INSPECTION AND DOCUMENTATION	:
	11.9	PREPARATION OF FINAL DOCUMENTATION PACKAGE	:
	11.10	TYPE TEST FACILITIES	:
	11.11	ACCEPTANCE TEST FACILITIES	:

Doc. Title	GENERAL CONDITIONS OF CONTRACT FOR SUPPLY ORDERS	
Rev. No		Page 43 of 47

	11.12	CALIBRATION OF INSTRUMENTS AND GAUGES (WITH TRACEABILITY TO NATIONAL STANDARDS) (ATTACH LIST)	:
	11.13	STATUTORY APPROVALS LIKE BIS, IBR, ETC.(AS APPLICABLE)	:
	11.14	SUB-VENDOR APPROVAL SYSTEM AND QUALITY CONTROL	:
	11.15	DETAILS OF TESTS CARRIED OUT AT INDEPENDENT RECOGNISED LABORATORIES	:
		i) FURNISH LIST OF TESTS CARRIED OUT AND THE NAME OF THE LABORATORY WHERE THE TESTS WERE CONDUCTED	:
		ii) CHECK AVAILABILITY OF CERTIFICATES AND REVIEW THESE WHEREVER POSSIBLE	:
12.0		EXPERIENCE (INCLUDING CONSTRUCTION / ERECTION / COMMISSIONING) TO BE FURNISHED IN THE FORMAT INDICATED IN APPENDIX)	:
13.0		SALES, SERVICE AND SITE ORGANISATIONAL DETAILS	:
14.0		CERTIFICATE FROM CUSTOMERS (ATTACH COPIES OF DOCUMENTS)	:
15.0		POWER SITUATION	:
16.0		LABOUR SITUATION	:
17.0		APPLICABILITY OF SC/ST RELAXATION (Y/N) IF YES, SUPPORTING DOCUMENTS TO BE ATTACHED	
Part C Supporting Documents			

Doc. Title	GENERAL CONDITIONS OF CONTRACT FOR SUPPLY ORDERS	
Rev. No		Page 44 of 47

18.0	<p>DOCUMENTS TO BE ENCLOSED:</p> <ol style="list-style-type: none"> 1. Factory License 2. ISO Certificate 3. Registration of Central Excise 4. Income Tax Clearance. 5. PF Registration 6. ESI Registration 7. Insurance for Workman Compensation Act No. 8. Electrical Contract LIC No. 9. PAN No. 10. GST Registration 11. MSME Certification 12. WC Tax Registration 13. Organogram of Co. having organogram of Design, safety, quality, production and other teams. 14. Details of subscription of BIS, IEC, IEE, ASTM or other. 15. Details of the team in Design, Quality, Safety, Production. 16. List of manufacturing equipment as per Part C. 17. List of calibrated equipment as per Part C. 18. List of clients and order executed in past two years. 19. Complaint escalation matrix. 20. Performance Certificates of same product from Minimum two utilities. 21. e-Payment Form as per enclosed Annexure-G 	
-------------	---	--

*** Classification of BAs under SC/ST shall be governed under following guidelines:**

- **Proprietorship/ Single Ownership Firm:** Proprietor of the firm should be from SC/ST community. Governing document shall be Proprietorship Deed.
- **Partnership Firm:** Only such firms shall qualify which have SC/ST partners holding equal to or more than 50% of the total ownership pattern of the firm. Governing document shall be Partnership Deed.
- **Private Limited Company:** Only such firms shall qualify which have SC/ST directors holding equal to or more than 50% of the total ownership pattern of the firm. Governing document shall be Memorandum of Understanding (MoU) and/or Article of Association (AoA).
- The relaxation available for BAs under SC / STs shall be as per GCC for Tender Fees, EMD, PBG and Turnover criteria.

NOTE: Certification from SC/ST Commission shall be required for deciding upon SC/ST status of a person.

Annexure-G (e-Payment detail form) must be filled by Associate along with this form.

Doc. Title	GENERAL CONDITIONS OF CONTRACT FOR SUPPLY ORDERS	
Rev. No		Page 45 of 47

ANNEXURE-I
MANUFACTURER AUTHORIZATION FORM

(To be submitted on OEM's Letter Head)

Date:

Tender Enquiry No.:

To,
Chief (Contracts & MM)
TPNODL,
Balasore

Sir,

WHEREAS M/s. *[name of OEM]*, who are official manufacturers of having factories at *[address of OEM]* do hereby authorize M/s *[name of bidder]* to submit a Bid in relation to the Invitation for Bids indicated above, the purpose of which is to provide the following Goods, manufactured by us

.....and to subsequently negotiate and sign the Contract.

We hereby extend our full guarantee and warranty in accordance with the Special Conditions of Contract or as mentioned elsewhere in the Tender Document, with respect to the Goods offered by the above firm in reply to this Invitation for Bids.

We hereby confirm that in case, the channel partner fails to provide the necessary services as per the Tender Document referred above, M/s *[name of OEM]* shall provide standard warranty on the materials supplied against the contract. The warranty period and inclusion / exclusion of parts in the warranty shall remain same as defined in the contract issued to their channel partner against this tender enquiry.

Yours Sincerely,

For

Authorized Signatory

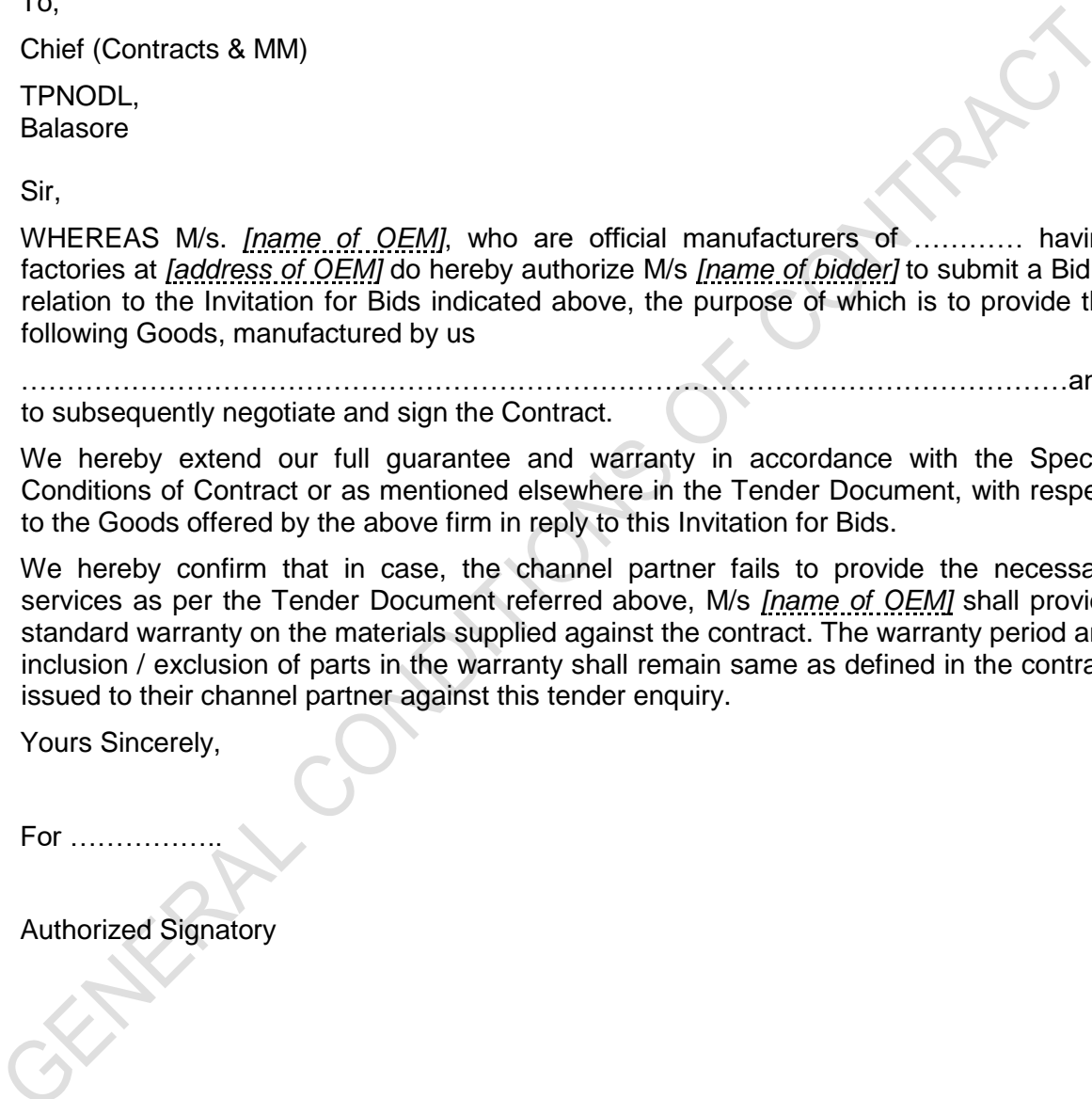

Doc. Title	GENERAL CONDITIONS OF CONTRACT FOR SUPPLY ORDERS	
Rev. No		Page 46 of 47

Annexure-J

TATA CODE OF CONDUCT (TCoC)

Introducing Tata Code of Conduct (TCoC) in GCC, the following clause is proposed for inclusion as per suggestions from Chief Ethics Counsellor -

“TCoC is the overarching policy framework that applies to all TATA Group companies including TPNODL. TCoC provides for stakeholder-wise approach in each of the seven chapters.

The chapter “Our Value Chain Partners” states the policy as follows:

1. We shall select our suppliers and service providers fairly and transparently.
2. We seek to work with suppliers and service providers who can demonstrate that they share similar values. We expect them to adopt ethical standards comparable to our own.
3. Our suppliers and service providers shall represent our company only with duly authorized written permission from our company. They are expected to abide by the Code in their interactions with, and on behalf of us, including respecting the confidentiality of information shared with them.
4. We shall ensure that any gifts or hospitality received from, or given to, our suppliers or service providers comply with our company’s gifts and hospitality policy.
5. We respect our obligations on the use of third party intellectual property and data.

In case any Ethical Concern is faced during the course of your business dealings BA can write to Chief- Contracts & MM and CEO.

TPNODL is committed to follow Core Values and Core Principles mentioned in TCoC, cited below, in carrying out various activities as well as in discharge of bi-lateral and multi-lateral obligations involving other entities/organizations:

Core Values:

All six core values are already mentioned in GCC.

Core Principles:

1. **Zero tolerance to bribery or corruption** in any form.
2. Committed to **good corporate citizenship**
3. Contribute to the **economic development of the communities** of the countries & regions we operate in.
4. No compromise on **Safety**
5. Our conduct shall be **fair & transparent**
6. Respect the **human rights & dignity** of our stakeholders
7. **No unfair discrimination** of any kind
8. Statements made to stakeholders shall be **truthful & made in good faith**
9. Not engage in any restrictive or **unfair trade practice**
10. Provide avenues for our stakeholders to **raise concerns in good faith**
11. Environment **free from fear** of retribution to deal with concerns that are raised
12. Expect the leaders to be **role model**

Doc. Title	GENERAL CONDITIONS OF CONTRACT FOR SUPPLY ORDERS	
Rev. No		Page 47 of 47

13. Comply with the laws of the countries in which we operate

Gift Policy:

Principles for acceptance of gifts/benefits –

A gift or benefit may be accepted only if it complies with all of the following principles:

- ✓ it does not influence,
- ✓ does not have the potential to influence, an employee in such a way as to compromise or appear to compromise integrity and impartiality
- ✓ does not create a conflict of interest or perception of conflict of interest;

Principles for non-acceptance of gifts/benefits -

The gift or benefit may not be accepted or given if any of the following principles apply:

- ✓ causes the recipient or donor **to act in partial manner** in the course of duty
- ✓ apprehension of the recipient becoming **obligated to the donor**
- ✓ it is **not offered openly**
- ✓ if is an **offer of money** or something readily convertible to money (e.g. Shares)

Violation –

1. Not abiding with this policy would constitute violation of “Our Employees” Stakeholder group Clause “Gifts and Hospitality” of the Tata Code of Conduct (TCoC) 2015. Prompt action will be taken against violations.
 2. Any deviation from this policy must be supported by appropriate rationale and must be duly approved by CEO who is also the Principal Ethics Officer. In any case, in dealing with such deviations, the spirit of the TCoC should in no case be compromised.
2. If it is determined that an employee / associate has violated this policy, appropriate action including termination of the employee’s / associate’s employment or association with TPNODL may be decided upon.